

RoHS

REV.	DESCRIPTION	DATE
A	ISSUE	Apr/19/2013
B	Change design.	Jul/30/2013

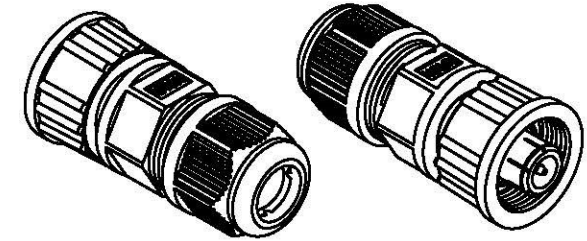

#2 Zipper PE Bag.

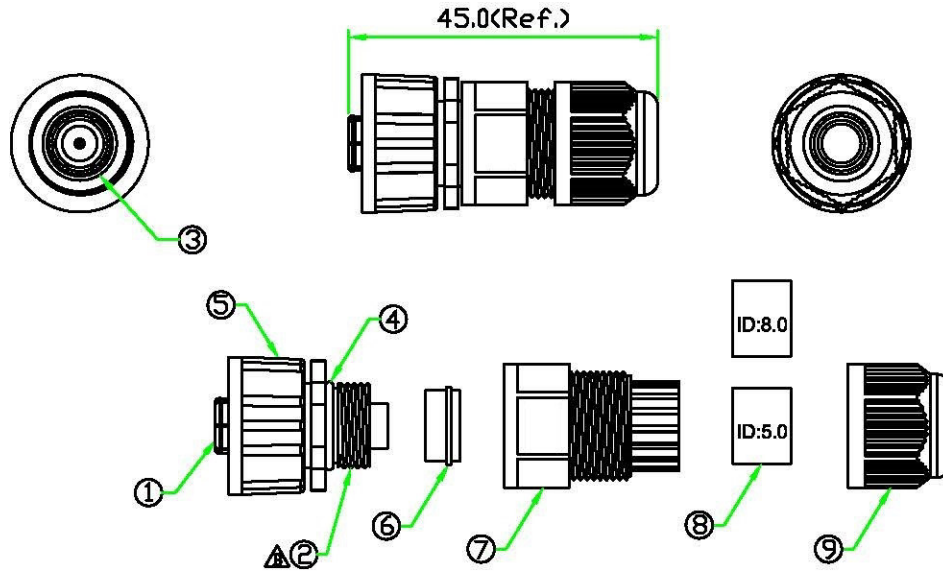
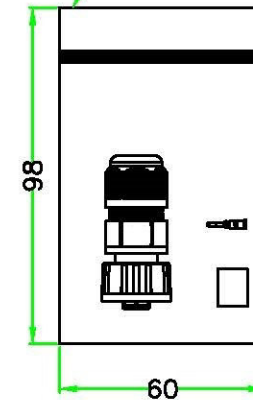

9	CLAMP NUT	NYLON.	BLACK	1	CBAS-CLAMP (70-135)
8	L SEAL	RUBBER, (Suitable for cable OD= 3~5 & 5 ~ 8mm.)	BLACK	2	CBAS-LSEAL (71-135)
7	HOOD	NYLON.	BLACK	1	CBAS-HOOD (69-135)
6	S SEAL	RUBBER.	BLACK	1	CBAS-SSEAL (71-135)
5	SCREW NUT	NYLON+GF.	BLACK	1	B-SN (48-135)
4	O-RING	NBR.	BLACK	1	CBS-O-N
3	O-RING	VITON.	BLACK	1	M12-O-VK
2	CONNECTOR	CONNECTOR INSERT. NYLON+GF.	BLACK	1	143-135-N3
1	PLUG	BNC MALE CONNECTOR. CRIMP TYPE (FOR 5C-FB).		1	BNC-C008-NOBP7 -A
No.	PART NAME	DESCRIPTION	COLOR	QTY	REMARKS

Allconnectors
 www.allconnectors.de
 Tel.: 0049 711 7009503
 Fax: 0049 711 7009504
 info@allconnectors.de
 Rinderstraße 22

	UNIT: mm	TITLE : Circular B Size BNC Male Crimp Type Screw Type Field Installable Connector For 5C-FB Cable	DR. <i>ERJC</i>
SCALE	1:1		
UNLESS OTHERWISE SPECIFIED TOLERANCES: x ±0.25 xx ±0.1 xxx ±0.05 ANGLE ±1°x		P/N: CBNCB-P401SA	CH. <i>MJCHAE</i>
REV. B	SHEET 1/1	DWG.NO: CBNCB-P401SA	AP.