

N=Number of conacts

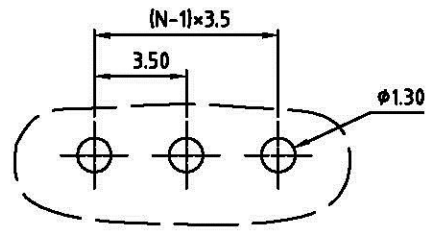

P.C.B. LAYOUT

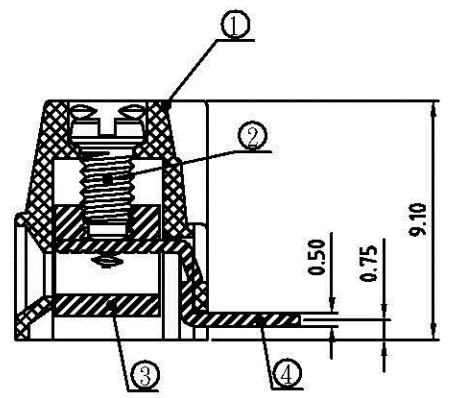

SECTION A-A

Material

- Item 1 Insulating body Thermoplastic (UL94V-0)
- Item 2 Terminal screw Steel Zinc plating "-" slot type
- Item 3 Terminal body Brass, Ni plated
- Item 4 Contact Brass, Tin plated

Electrical

- Voltage rating: 300VAC
- Current rating: 10A
- Wire range:
- Solid wire(AWG): 16-24
- Stranded wire(AWG): 16-24
- Torque(Lb-In): 1.7
- Screw: M2
- Wire strip length: 5-6mm
- Withstanding Voltage: 1.6KV
- Operating temperature: -30°C to +105°C
- Soldering temperature: 250°C±10°C/5 Sec

TBH035-R09-xx-LF
LEADFREE

RoHS Compliant

Allconnectors

www.allconnectors.de
Tel.: 0049 711 7009500
70704 Nilderstadt - Germany

info@allconnectors.de
Fax: 0049 711 7009504
Kettnerstr. 25

PART NO. TBH035-R09-xx

DWG NO. TBH035-R09-xx

CHECKED BY CY

FILE NO.

DRAWING BY

TOLERANCES ARE

.X ± 0.2
.XX ±
.XXX ±
AWG

DESCRIPTION:

UNIT / mm

SCALE 1:1

PROJECTION

AREA

REVISIONS

HK

DATE