

SPECIFICATIONS
 BODY MATERIAL: THERMOPLASTIC (UL 94V-0)GREEN
 TERMINALS: TIN PLATED BRASS
 SCREWS: NICKEL PLATED STEEL
 WIRE RANGE AWG: 18-24 STR
 RATING: 10AMPERES,300VAC
 INSULATION WITHSTANDS VOLTAGE AC 1500V
 INSULATION RESISTANCE 500M OR MORE AT DC 500V

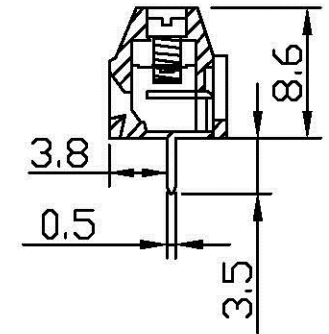
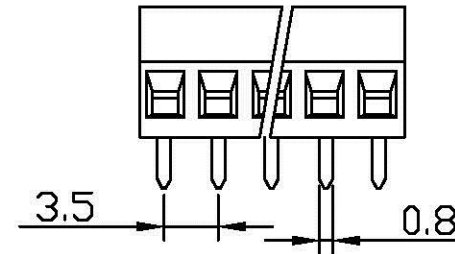
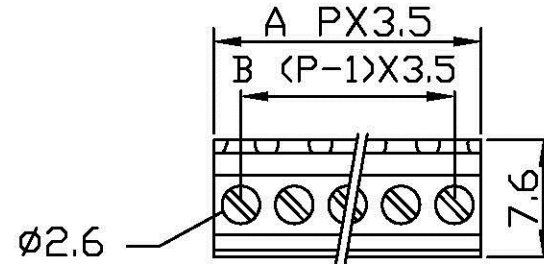
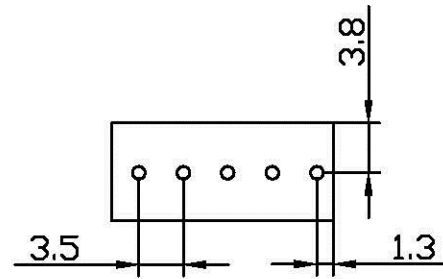

DIMENSION: ±0.5

POLE	2	3	4	5	6	7	8	9	10	11	12	13	14	15				
A	7	10.5	14	17.5	21	24.5	28	31.5	35	38.5	42	45.5	49	52.5				
B	3.5	7	10.5	14	17.5	21	24.5	28	31.5	35	38.5	42	45.5	49				
POLE	16	17	18	19	20	21	22	23	24	25	26	27	28	29	30	31	32	
A	56	59.5	63	66.5	70	73.5	77	80.5	84	87.5	91	94.5	98	---	---	---	---	
B	52.5	56	59.5	63	63.5	70	73.5	77	80.5	84	87.5	91	94.5	---	---	---	---	

Allconnectors

www.allconnectors.de
 Tel.: 0049 711 7009503
 70794 Filderstadt - Germany

info@allconnectors.de
 Fax: 0049 711 7009504
 Kettenstr. 25

PART NO. TBH035-D08-xx

DWG NO. TBH035-D08-xx

APPROVED BY CY

FILE NO.

DRAWING BY

TOLERANCES ARE

.X0.2
 .XX
 .XXX
 AWG

DESCRIPTION:

UNIT / mm

SCALE 1:1

PROJECTION



AREA

REVISIONS

HK

DATE