

WITHOUT CARD

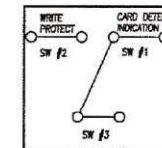

CARD INSERTED  
WRITE PROTECT : LOCK

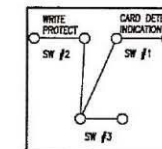

CARD INSERTED  
WRITE PROTECT : UNLOCK

**All Connectors**

www.allconnectors.de  
Tel.: 0049 711 7006509  
70794 Filderstadt - Germany

info@allconnectors.de  
Fax: 0049 711 7006501  
Kettenerstr. 25

**RoHS Compliant**

DRAWING BY CY  
CHECKED BY GENIUS  
UNIT / mm SCALE 1 : 1  
DATE  
SIZE A4

TOLERANCES ARE

X ±  
X ± 0.30  
XX ± 0.20  
XXX ± 0.05  
ANG ±

PROJECTION



**ORDER INFORMATION**

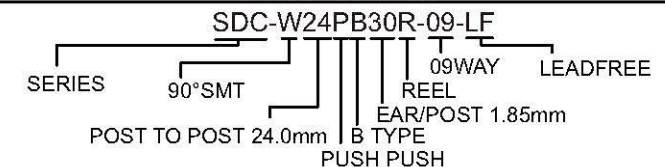

**DESCRIPTION:**

SD MEMORY CARD PUSH-PUSH RIG  
SWITCH (#3) CONNECTOR TYPE D

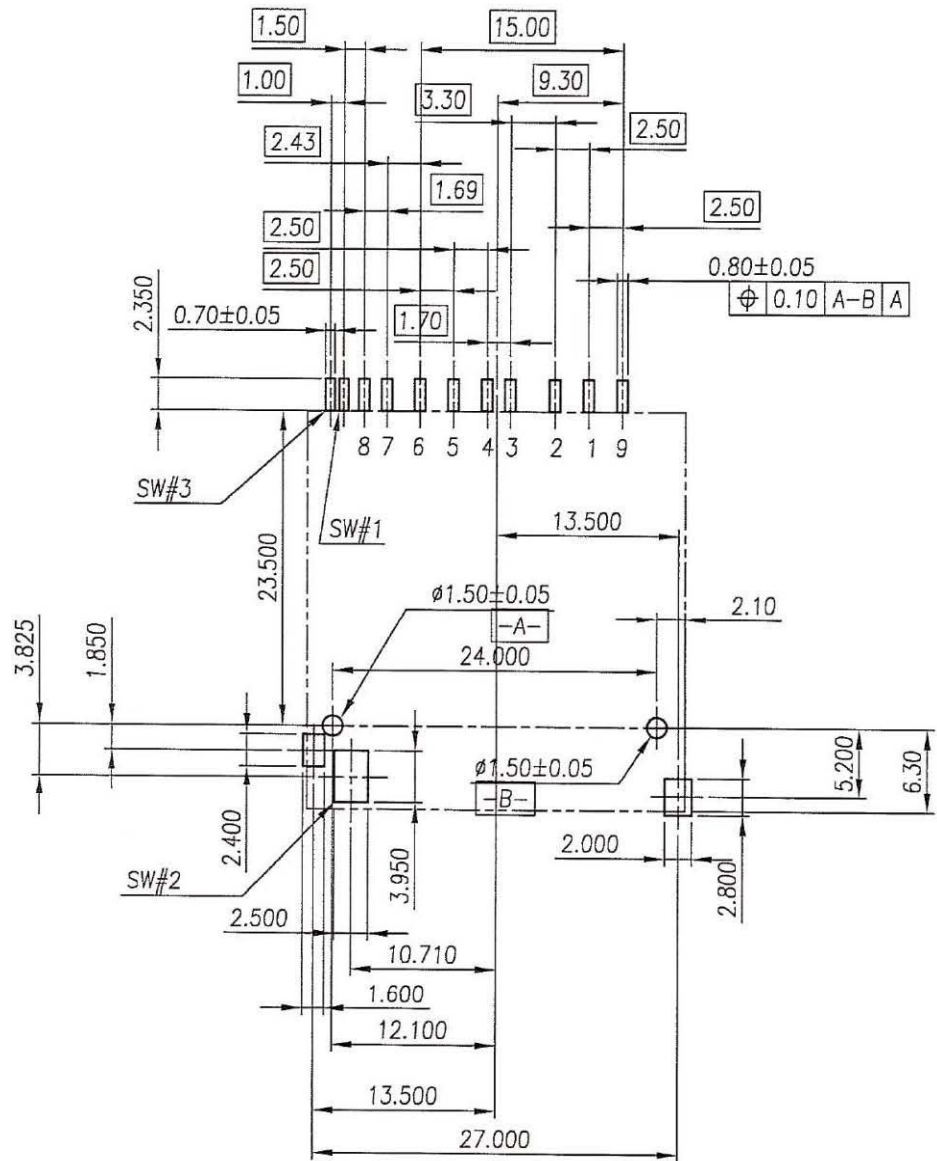

SD CARD PIN ASSIGN	
PIN	NAME
1	CD/DAT3
2	CMD/DI
3	VSS1
4	VDD
5	CLK/SCLK
6	VSS2
7	DAT0
8	DAT1
9	DAT2

**RoHS Compliant**

**All Connectors**

www.allconnectors.de  
Tel.: 0049 710 7003902  
70794 Filberstadt - Germany

info@allconnectors.de  
Fax: 0049 710 7003904  
Kalteneustr. 25

**DRAWING BY** CY  
**CHECKED BY** GENIUS

**UNIT/mm**    **SCALE** 1:1

**DATE**    **SIZE** A4

**TOLERANCES ARE**

X ±  
X ± 0.30  
.XX ± 0.20  
.XXX ± 0.05  
ANG ±

**PROJECTION**



**ORDER INFORMATION**

**SDC-W24PB30R-09-LF**

SERIES    90°SMT    POST TO POST 24.0mm    09WAY REEL    LEADFREE

B TYPE    EAR/POST 1.85mm    PUSH PUSH

**DESCRIPTION:** SD MEMORY CARD PUSH-PUSH RIG SWITCH (#3) CONNECTOR TYPE D

- 1-1. 成品置於COMPONENTS區,成品需朝同一方向置放
- 1-2. 端子朝向CARRIER TAPE 底部
- 1-1. PUT SD C TYPE CONN. IN COMPONENT AREA, CHAMFER OF SD.A TYPE IS THE SAME DIRECTION TO CARRIER TAPE.
- 1-2. CONTACT ARE TOWARDS TO THE BOTTOM OF CARRIER TAPE.

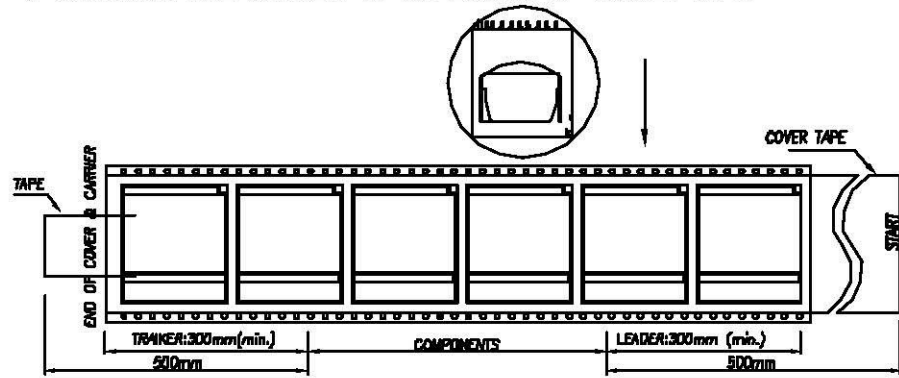

- 2-1. CARRIER & COVER 黏合(或熱壓合) CARRIER末端(END)以膠帶固定於HUB的 小的那一端),COVER朝向REEL的外側
- 2-2. LABEL貼於REEL外側 (標起點位置)
- 2-3. CARRIER不足一捲長度時(其包裝明細表)不可重 疊黏合使用
- 2-4. COVER TAPE 不可重疊黏合使用
- 2-5. 以透明膠帶將START(起點點)固定住
- 2-1. ADHERE OR HEAT COVER & CARRIER TAPE PUT THE END OF CARRIER ON THE "HUB'S" GATE, FIX WITH TRANSPARENT TAPE.
- 2-2. STICK LABEL ON OUTSIDE OF REEL, NEAR THE POSITION OF START SIDE OF COVER.
- 2-3. IF THE LENGTH OF CARRIER ISN'T LONG ENOUGH CONNECT TO USE AS PACKING LIST, COVER TAPE IS ALSO IN THE SAME CONDITION.
- 2-4. FIX THE COVER TAPE OF START WITH TRANSPARENT TAPE.

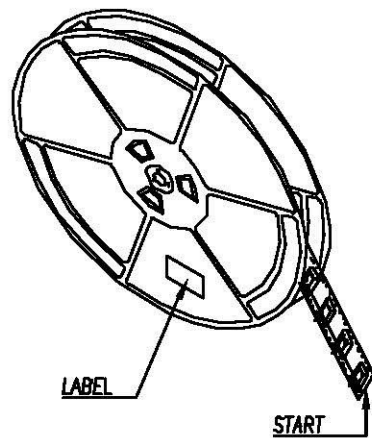

- 3-1. REEL之LABEL一表朝上.
- 3-2. 先置入一片EPE於內箱底部.
- 3-3. 將REEL平置於防水袋內,袋內放入2包乾珠,再置於內盒中.
- 3-4. 再置入一片EPE於REEL頂部.
- 3-5. 以TAPE封合,並貼上成品包裝標籤
- 3-1. PUT THE LABEL OF REEL UP.
- 3-2. PUT 1 PIECE OF EPE INTO BOTTOM OF BOX. THE LABEL OF REEL UP.
- 3-3. PUT 5 REELS AND 2 BAGS SILICA GEL INTO PE BAG. THEN PUT DOWN IN BOX, AFTER PE BAG WAS CLOSED.
- 3-4. PUT 1 PIECE OF EPE ON TOP OF P.E. BAG
- 3-5. CLOSE BOX AND SEAL WITH TAPE, STICK THE PRODUCT LABEL ON TOP SIDE OF BOX.

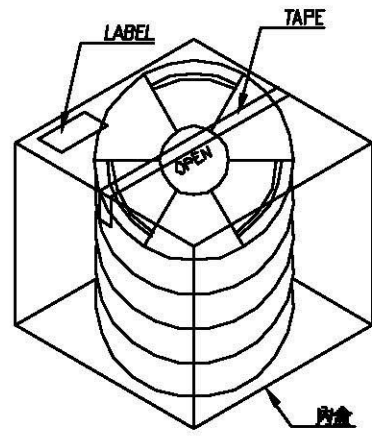

- 4-1. 每2個內盒置於一個外箱中.
- 4-2. 以TAPE封合,並貼上成品包裝標籤
- 4-1. PUT INTO 2 BOXES IN ONE CARTON.
- 4-2. SEAL WITH TAPE AND STICK PRODUCT LABEL ON LEFT SIDE.

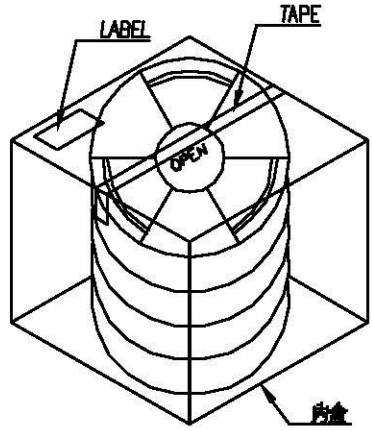

**All Connectors**

www.allconnectors.de  
Tel.: 0049 711 7007530  
70794 Filzdenstadt - Germany

info@allconnectors.de  
Fax: 0049 711 7007504  
celliers@allconnectors.de

**RoHS Compliant**

**TOLERANCES ARE**

DRAWING BY	CY	X ±
CHECKED BY	GENIUS	X ±
UNIT / mm	SCALE 1 : 1	.XX ±
DATE		.XXX ±
SIZE A4	P PROJECTION	ANG ±



**ORDER INFORMATION**

SDC-W24PB30R-09-LF

SERIES 90°SMT REEL LEADFREE

POST TO POST 24.0mm EAR/POST 1.85mm B TYPE PUSH PUSH

DESCRIPTION: