

REMARK : RoHS REQUIREMENT APPLIED
(符合RoHS)

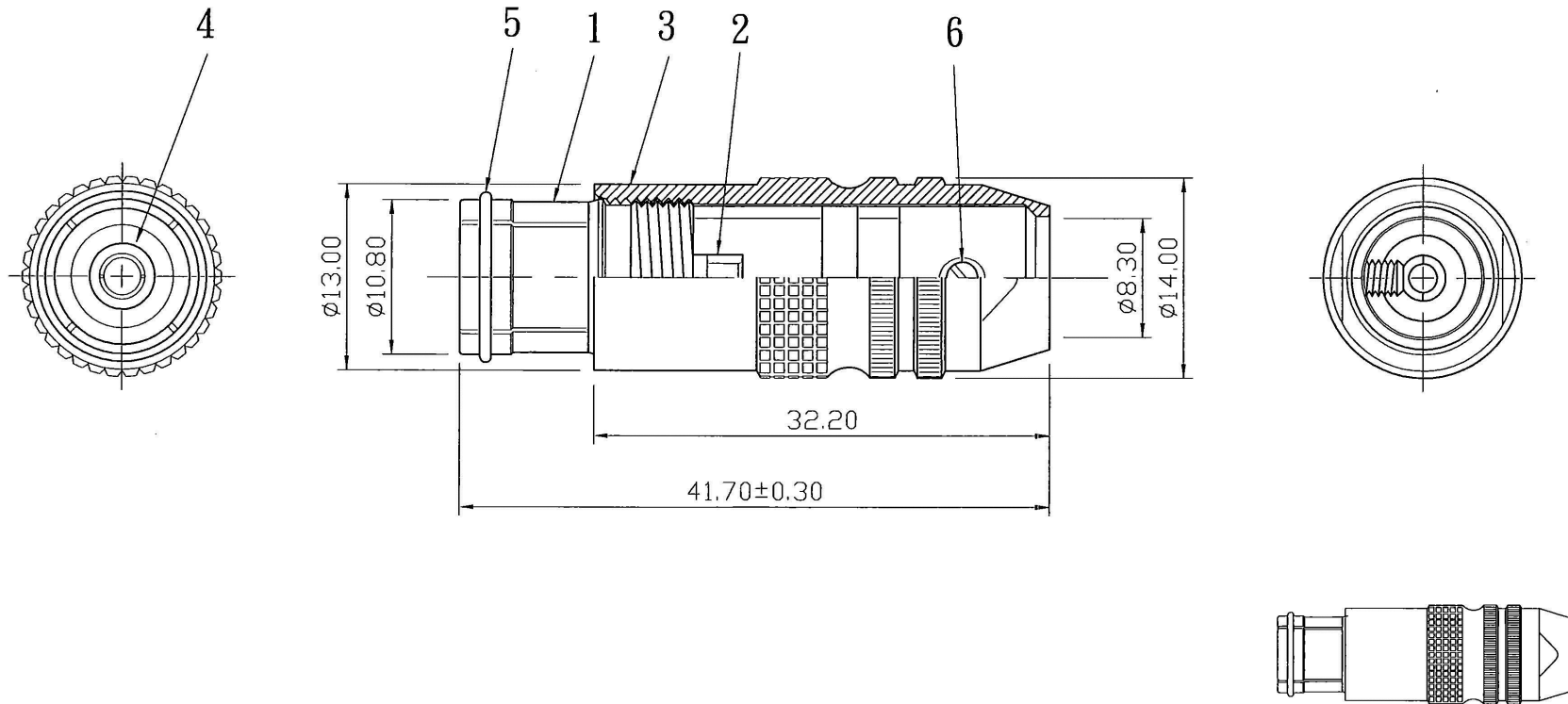

S1:1

NO.	Description	Unit	Materials	Finish	Drawing No.	SCALE	2:1	UNIT	MM	CHECKED	DATE	FILE NO.
7										DIMENSIONS ARE IN MILLIMETERS UNLESS OTHERWISE PECIFIED TOLERANCES (一般公差) 0.5~6 = ±0.2 >6~30 = ±0.4 >30~120 = ±0.6 >120~315 = ±1 >315~1000 = ±1.6 ANGLES(角度) = ±5°	2008.01.02	DRAWINGVAUDIO\TV\TV-103ZAG-TEF-FEMALE-A-8.3
6	screw	1	brass	gold	SCREW-102G-M2.6XP0.45X3.5mm				工程師			
5	C washer	1	brass	gold					MAY 9 2014			
4	insulator	1	PTFE	white					馬正成			
3	shell	1	brass	zinc alloy								
2	contact pin	1	brass	gold								
1	body	1	brass	gold								
						Allconnectors				www.allconnectors.de Tel.: 0049 711 7009503 70794 Filderstadt - Germany info@allconnectors.de Fax: 0049 711 7009504 Kettnerstr. 25		
						TITLE		TV PLUG		DRAWING NO.		TV-103ZAG-TEF-FEMALE-A-8.3