

No.	DATE	DESCRIPTION	REV	REMARK : RoHS REQUIREMENT APPLIED (符合RoHS)	DATE	DRAWING NO.
-----	------	-------------	-----	---	------	-------------

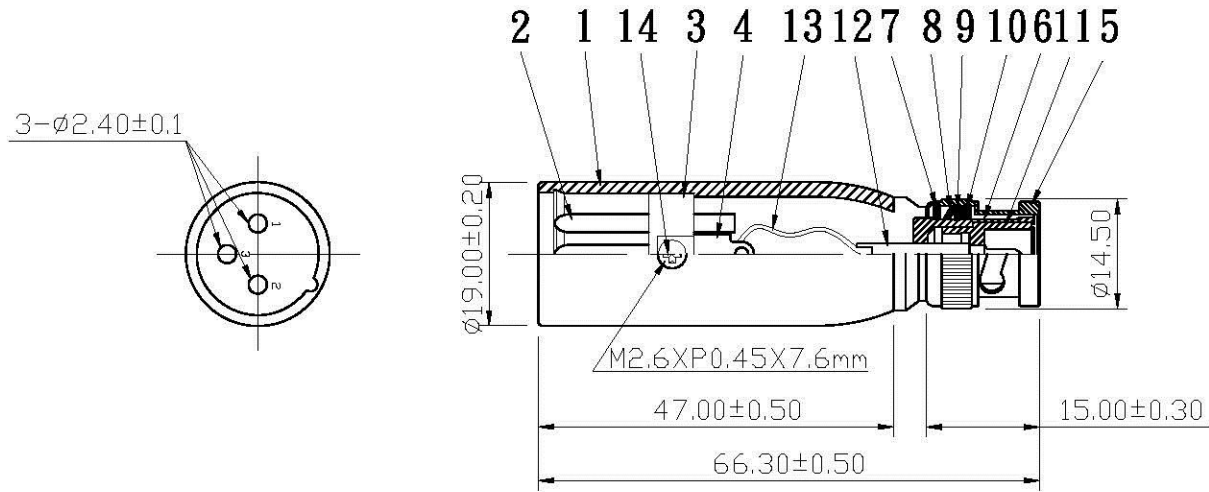

14	screw	1	iron	nickel	SCREW-305N-M2.6XP0.45X7.6mm
13	cable	1	pvc	white	
12	contact pin	1	brass	gold	
11	insulator	1	delrin	white	
10	gasket	1	rubber	nickel	
9	washer	1	steel	nickel	
8	spring	1	SK-5	nickel	
7	washer	1	steel	nickel	
6	body	1	brass	nickel	
5	shell	1	brass	nickel	
4	solder tab	1	bronze	nickel	
3	insulator	1	PBT+30%fiber	gray	
2	contact pin	3	brass	nickel	
1	shell	1	zinc alloy	nickel	
NO.	Description	Unit	Materials	Finish	Drawing No.

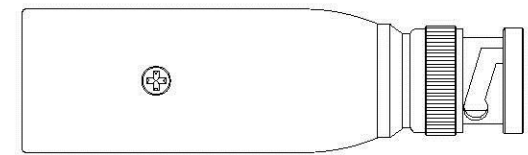

S 1 : 1

DIMENSIONS ARE IN MILLIMETERS UNLESS OTHERWISE PECIFIED TOLERANCES (一般公差) 0.5~6 = ±0.1 >6~30 = ±0.15 >30~120 = ±0.2 >120~315 = ±0.3 >315~1000 = ±0.4 ANGLES(角度) = ±3°	APPROVED	All Connectors www.allconnectors.de Tel.: 0049 711 7009503 70754 Filberstadt - Germany info@allconnectors.de Fax: 0049 711 7009504 Kettenerstr. 25
	CHECKED	
	DRAWN <i>Wing</i>	
	DATE 2008. 09. 25	
SCALE 1 : 1 UNIT MM	TITLE MICROPHONE MALE TO BNC MALE	FILE NO. DRAWINGRFADTADT-2801S-MI10PB-BC10DA