

REV.	DESCRIPTION	ECN NO.	DATE	DRAWER
A	New Release		03/23/2006	Tom
B	Add Packing $\triangle_B \times 3$	EC0903068	03/25/2009	Steven

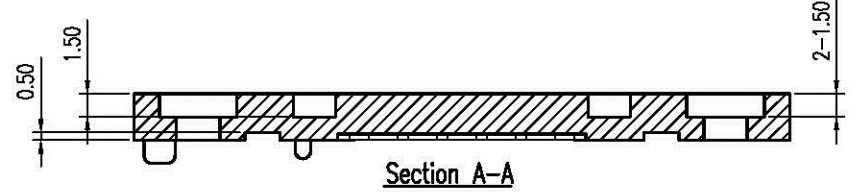

- Notes:**
- Material :  
Housing : Thermoplastic UL 94V-0, Black  
Terminal : Copper Alloy
  - Finish :  
Terminal : 20u" Gold, 50u" Ni Under-plated Overall
  - Order Information :  
TPE0-03130-70 X 6

**Packing**  
 Y : Tray  
 $\triangle_B$  5 : Tray + Cap  
 2 : Reel + Cap

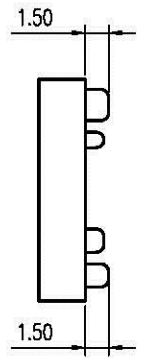
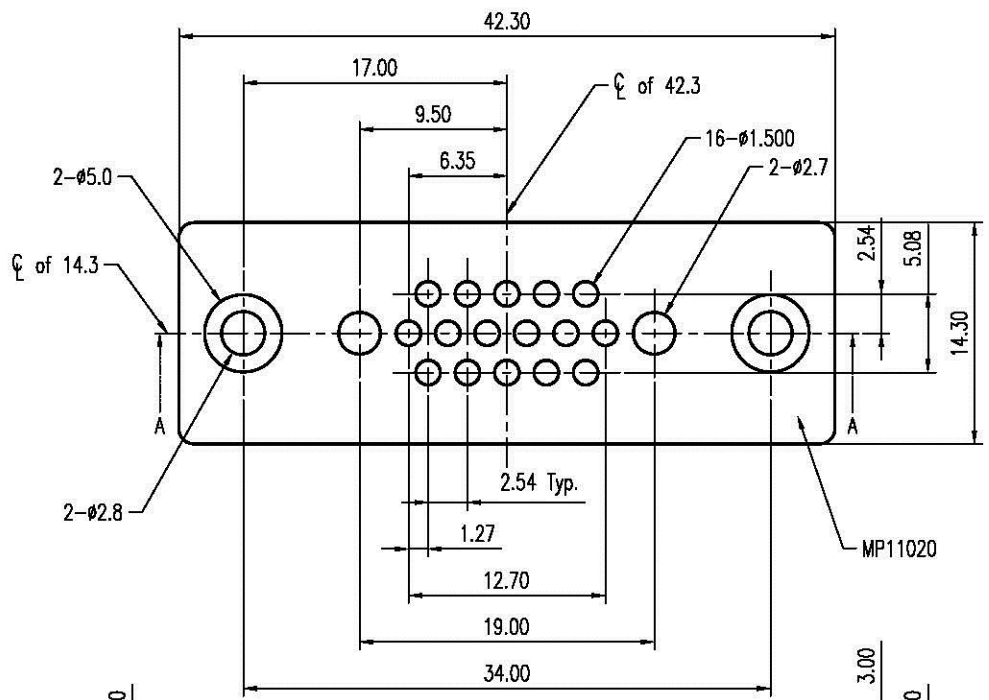
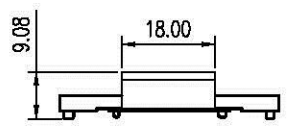
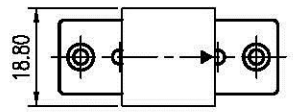
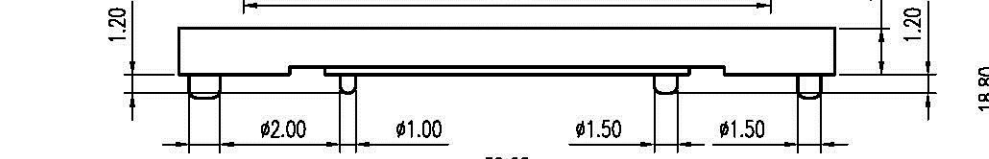

$\triangle_B$  With Cap

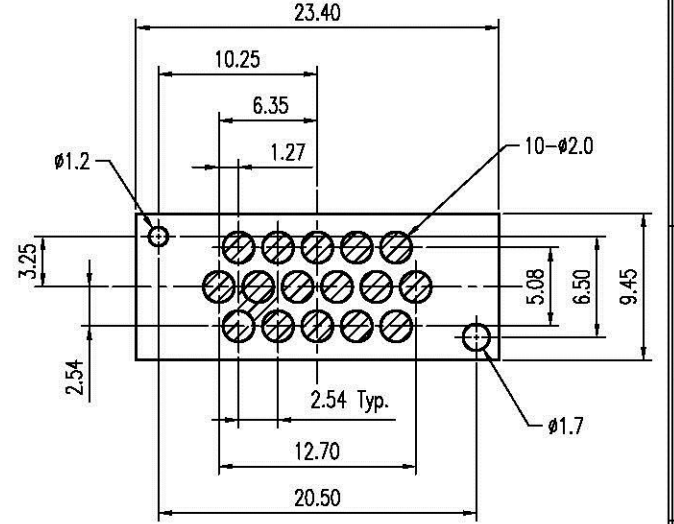

**Recommended P.C.B. Layout**  
 Layout Tolerance =  $\pm 0.05$  mm

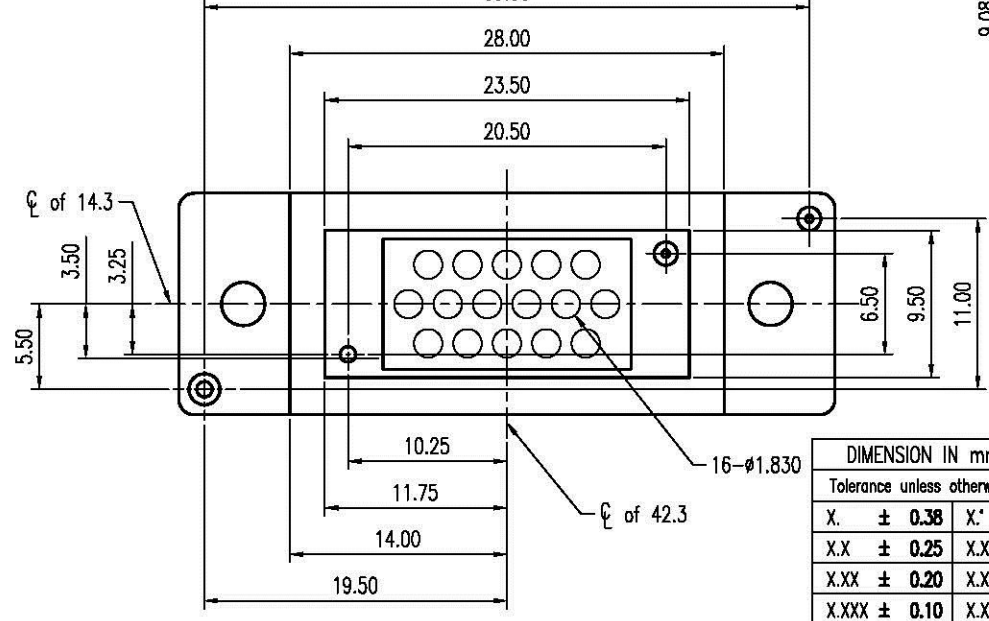

DIMENSION IN mm [inch]			
Tolerance unless otherwise specified			
X.	$\pm 0.38$	X.'	$\pm 10'$
X.X	$\pm 0.25$	X.X'	$\pm 5'$
X.XX	$\pm 0.20$	X.XX'	$\pm 2'$
X.XXX	$\pm 0.10$	X.XXX'	$\pm$

**All Connectors**

www.allconnectors.com  
 Tel: 0049 711 7005503  
 70729 Filderstadt - Germany

info@allconnectors.com  
 Fax: 0049 711 7005504  
 Kettnerstr. 25

**CUSTOMER DRAWING**

Approver: \_\_\_\_\_ Checker: \_\_\_\_\_

Title	2.54mm Pitch Plane Conn. 16 Pins SMT Type		
Dwg No.	TPE0-03130-70X6 $\triangle_B$		
File No.	PO2017		Scale: 2 : 1
Drawer:	Steven		Size: A 4
Rev:	03/25/2009		Rev : B
			Sheet: 1 / 1