

TABLE A

GOLD 15u"	BRIGHT TIN	材料
CONTACT	SOLDER	SHELL

1. MATERIAL :

- 1-1. HOUSING : NYLON 66 UL94V-0 ; COLOR : BLACK
- 1-2. CONTACT : PHOSPHOR BRONZE
- 1-3. FIXED : LCP UL94-V0 (BLACK)
- 1-4. METAL UP COVER : STAINLESS
- 1-5. METAL DOWN COVER : STAINLESS
- 1-6. PLASTIC COVER : NYLON 66 UL94V-0 ; COLOR : BLACK

2. FINISH :

- 2-1. CONTACT :
CONTACT AREA : SEE TABLE A
SOLDER AREA : SEE TABLE A
UNDER PLATE : NICKEL
- 2-2. CONTACT :
SHELL : SEE TABLE A

RoHS Compliant

All Connectors

www.allconnectors.de info@allconnectors.de
Tel.: 0049 711 7009503 Fax: 0049 711 7009504
70794 Filderstadt - Germany Kettnerstr. 25

DRAWING BY CY
CHECKED BY GENIUS
UNIT/mm SCALE 1:1
DATE
SIZE A4

TOLERANCES ARE

X ±
.X ± 0.20
.XX ± 0.10
.XXX ± 0.05
ANG ± 1°

PROJECTION



ORDER INFORMATION

PCM-PA-26-LF
SERIES | LEADFREE
26WAY
ASSEMBLY
MALE

DESCRIPTION: PCMCIA 26(M) 雄式

步驟一:

1. 將成品放入PE袋
2. 每個包裝好的PE袋以熱封機熱封
數量SEE TABLE A

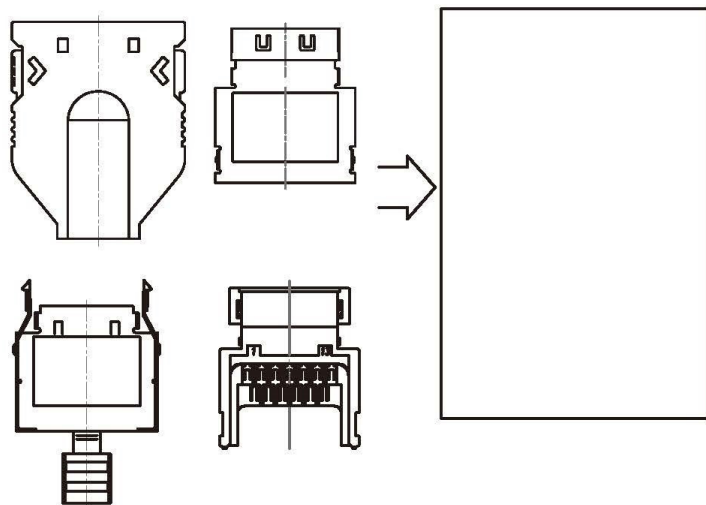

步驟二:

1. 一個紙箱可以裝10個PE袋
2. 每箱數量SEE TABLE A
3. 將PE袋放紙箱中, 後封箱.

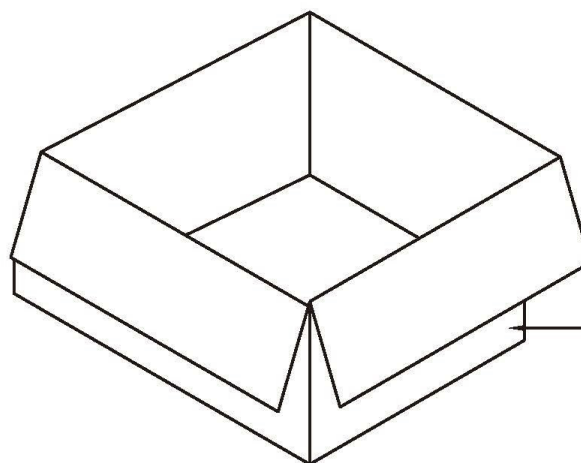

紙箱

步驟三:

1. 用膠帶將紙箱封實.
2. 將標籤貼於紙箱上.

標籤處

ITEM NO:	
QTY:	PGS
N. W. :	KG
G. W. :	KG
MEAS:	

C/NO. :

CARTON SIZE 500 pcs	
34*23.5*22.5	
N.W. : 2.50kgs	G.W. : 3.00kgs

All Connectors

www.allconnectors.de info@allconnectors.de
Tel.: 0049 711 7009503 Fax: 0049 711 7009504
70794 Filderstadt - Germany Kettenerstr. 25

RoHS Compliant

DRAWING BY CY
CHECKED BY GENIUS
UNIT/ mm SCALE 1:1
DATE
SIZE A4

TOLERANCES ARE

X ±
.X ± 0.20
.XX ± 0.10
.XXX ± 0.05
ANG ± 1°

PROJECTION



ORDER INFORMATION

PCM-PA-26-LF
SERIES | LEADFREE
26WAY
ASSEMBLY
MALE

DESCRIPTION: PCMCIA 26(M) 轉配式