

This document is the property of Nian-Yeong Corporation and is delivered on the express condition that it is not to be disclosed, reproduced or used, in whole or in part, for manufacture or sale by anyone other than Nian-Yeong Corporation without its prior consent, and that no right is granted to disclose or to use any information in this document.

CUSTOMER DRAWING

REV.	DESCRIPTION	APPVL. BY	DATE	ECN NO.
A	CHANGE DRAW	Stewart	09/08/04'	
B	Datum Line to Explain.	Stewart	11/27/06'	
C	Add Tolerance.	Stewart	01/18/07'	
D	修正尺寸	Stewart	03/17/08'	
E	新增 P.C.B.LAYOUT	Stewart	25/03/08'	
F	新增塑膠隔欄	Fido	10/08/09'	ECN09129

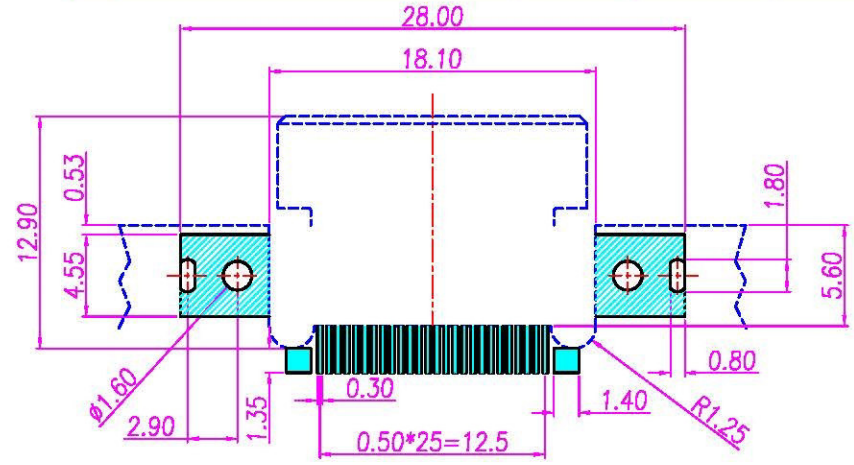
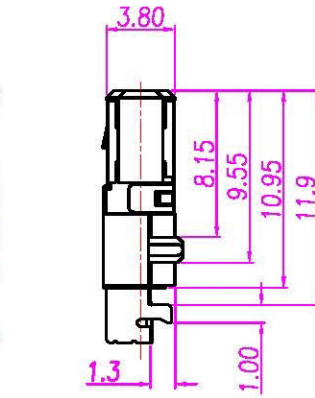
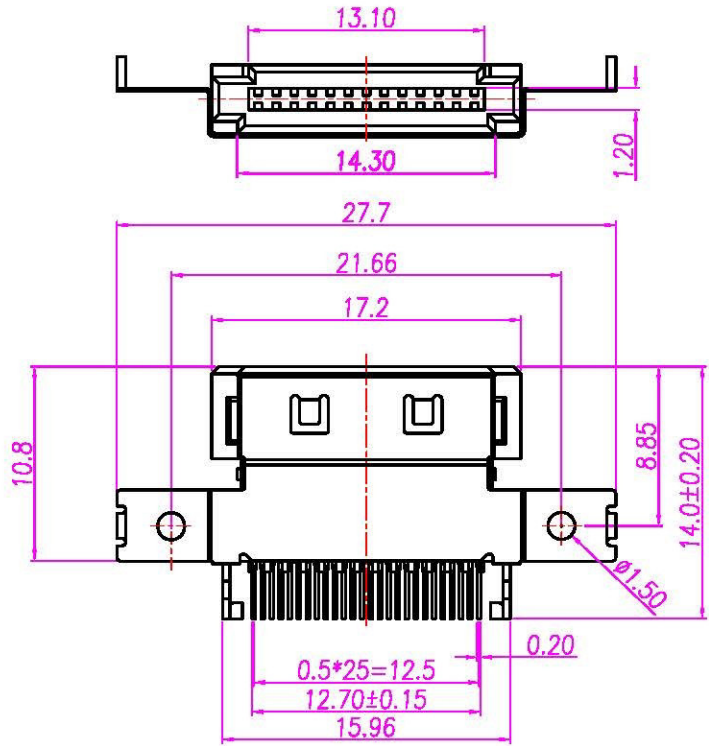

RECOMMEND P.C.B LAYOUT

- MATERIAL :
 - HOUSING : LCP UL94V-0 ; COLOR : BLACK
 - CONTACT : PHOSPHOR BRONZE
 - SHELL : PHOSPHOR BRONZE
 - GROUND : BRASS.
- FINISH :
 - CONTACT :
 - CONTACT AREA : 30 MICRO INCHES MIN. GOLD PLATED
 - SOLDER AREA : BRIGHT TIN
 - UNDER PLATE : NICKEL
 - SHELL : MATTE TIN
 - UNDER PLATE : NICKEL
 - GROUND : BRIGHT TIN
 - UNDER PLATE : NICKEL

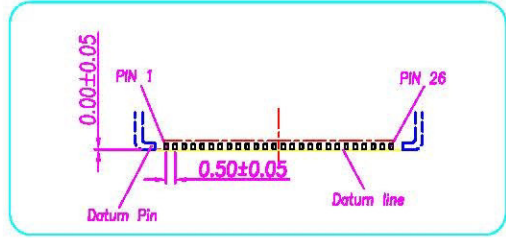
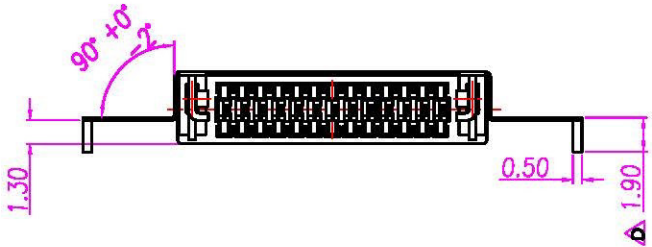

DRAW	Yeh Chou	APPVL	UNIT	MM	TOLERANCE		TITLE	PCMCIA 26PIN B TYPE			SHEET
CHECK			SCALE	1:1	XX ±0.20 XXX ±0.10 XXXX ±0.05 XXXXX ±0.03 ANGULA ±1°		PART NO.	PC-26M4-01	DWG NO.	QC0620	VERSION
ENTERPRISE CO., LTD.											F