

This document is the property of Nan-Yeong Corporation and is delivered on the express condition that it is not to be disclosed, reproduced or used, in whole or in part, for manufacture or sale by anyone other than Nan-Yeong Corporation without its prior consent, and that no right is granted to disclose or to use any information in this document.

CUSTOMER DRAWING

REV.	DESCRIPTION	APPVL. BY	DATE	ECN NO.
A	RELEASE	Fido Veng	14/01/08*	
B				
C				

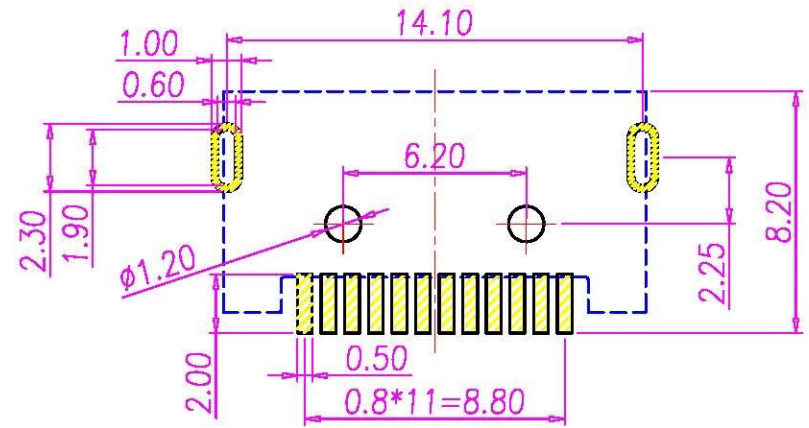
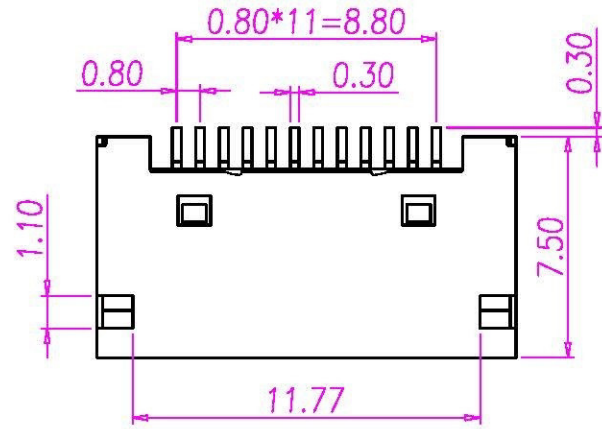

Recommend P.C.B Layout

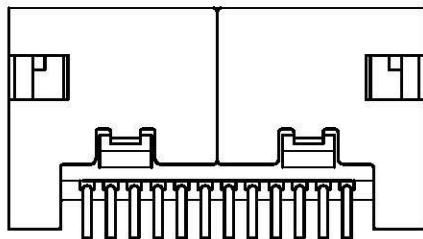
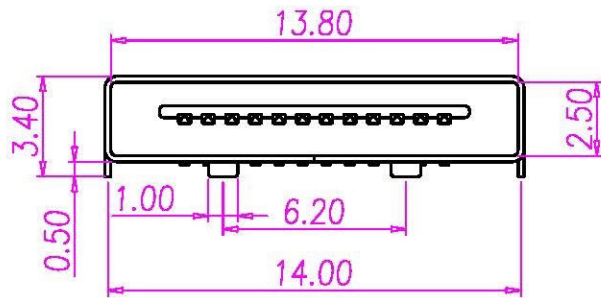
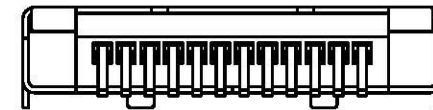

- MATERIAL :
 - HOUSING : LCP UL94V-0 ; COLOR : BLACK
 - CONTACT : PHOSPHOR BRONZE
 - SHELL : STAINLESS
- FINISH :
 - CONTACT :
 - CONTACT AREA : 10 MICRO INCHES MIN. GOLD PLATED
 - SOLDER AREA : BRIGHT TIN
 - UNDER PLATE : NICKEL
 - SHELL : NICKEL PLATED
- ELECTRICAL SPECIFICATION :
 - RATED CURRENT : 0.5A
 - RATED VOLTAGE : AC 30Vr.m.s
- ENVIRONMENTAL :
 - OPERATION TEMPERATURE : -25°C~75°C

DRAW	APPVL	UNIT	PR	TOLERANCE	www.allconnectors.com		TITLE	PCMCIA 12(F)SMT 短脚			SHEET
CHECK		SCALE	1:1	X ±0.20 XX ±0.10 XXX ±0.05 XXXX ±0.03 ANGULA ±1°	 Tel: 0049 711 709508 70724 Filderstadt - Germany info@allconnectors.com Fax: 0049 711 709504 kettenstr. 25		PART NO.	PC-12F4-03	DWG NO.	QC1386	 VERSION A