

KEY ID "M"
RECOMMENDED P.C.BOARD LAYOUT

420NGFF CARD 42mm TYPE
600NGFF CARD 60mm TYPE
800NGFF CARD 80mm TYPE
1100NGFF CARD 110mm TYPE

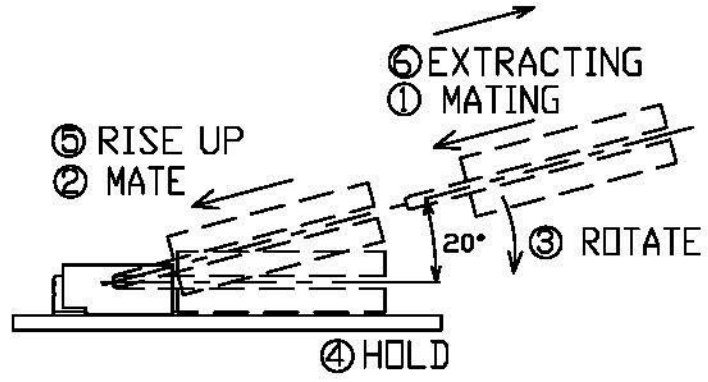
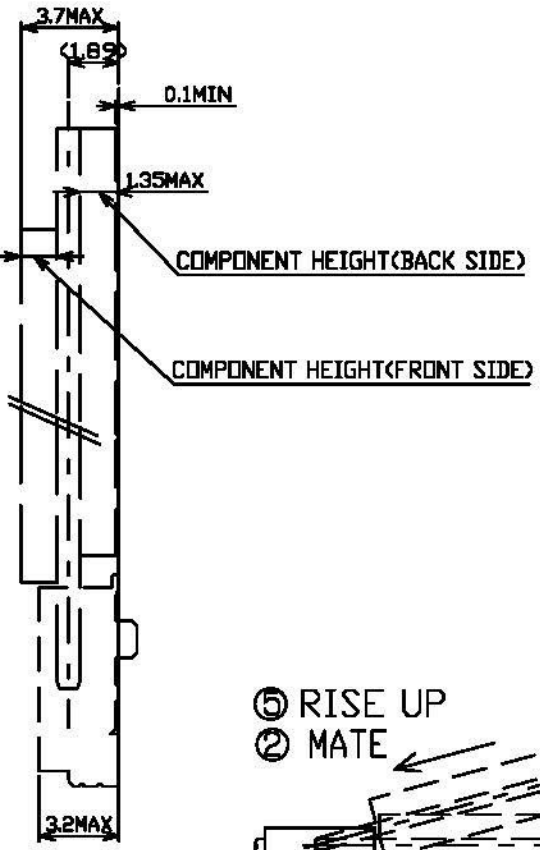

						UNLESS OTHERWISE SPECIFIED TOLERANCE				
						ANGLES	ANG.	+SP		
						LINEAR	0.0	±0.25		
							0.00	±0.20		
						SCALE	AS SHOWN	UNIT: mm		
						DRAWN	Willis	2013/12/09	DRAWN NAME: M.2 Connector Key M H:3.2mm	
						CHECKED	Angel	2013/12/09		
						APPROVED	Ken	2013/12/09		
						PRODUCT NO.	123A-32MA0-R01			
						FILE NAME	123A-32MA0-R01_B_1			
REV.	DESCRIPTION	DATE	REV.	DESCRIPTION	DATE	SIZE	A4	REV. 1.0		

- △ Revise:
- △ Revise:
- △ Revise:

DIRECTION OFF TOP OF REEL

NOTES:

1. THE DIRECTION OF EACH CONNECTOR ON A EMOSS IS REFERED TO THIS DRAWING.
2. GENERAL TOLERANCE ± 0.5 , $\pm 3^\circ$
3. PACKAGED IN EMOSS TAPE AND PLASTIC REEL 1200 PCS PRE REEL.

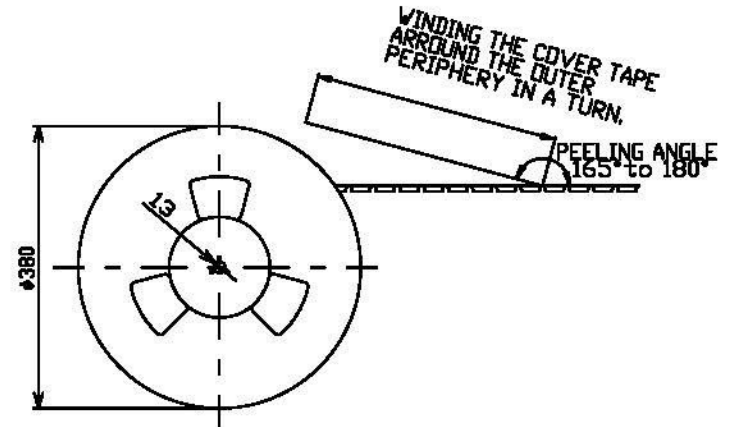
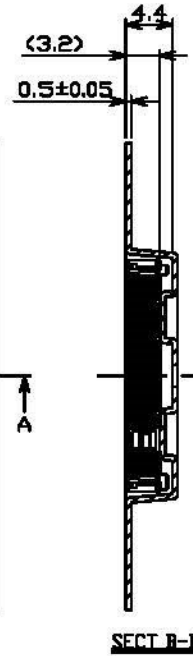
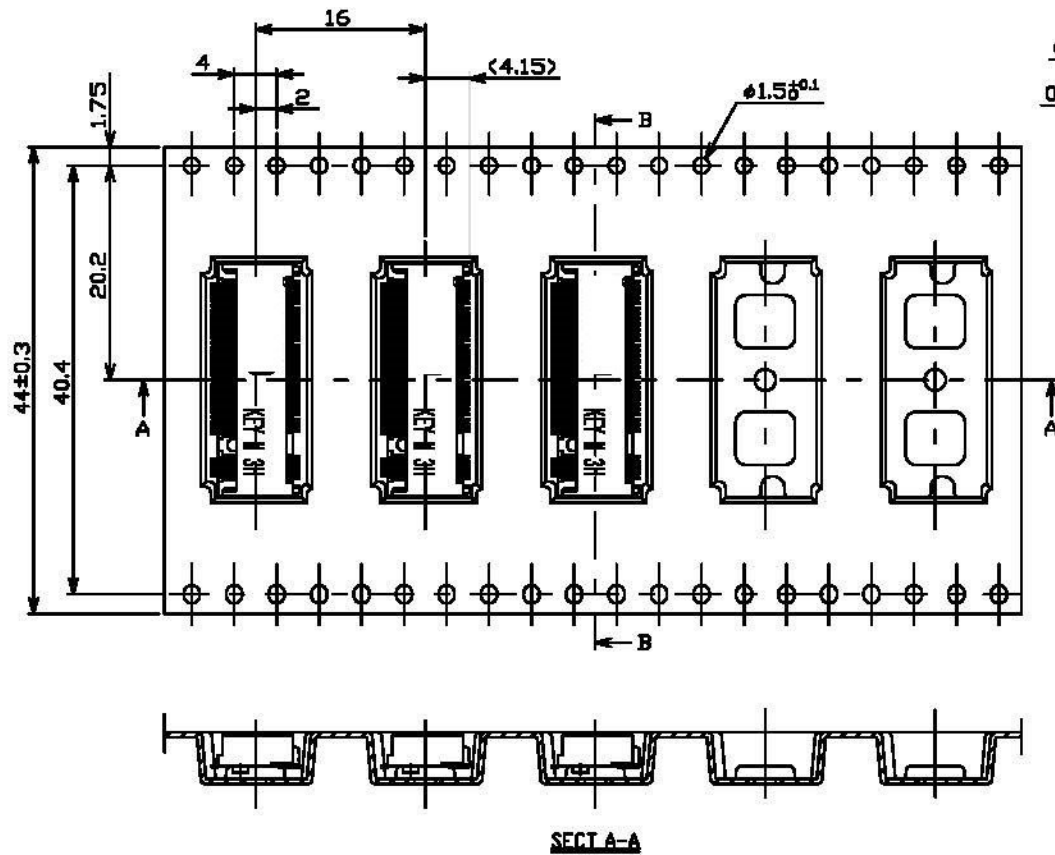

				UNLESS OTHERWISE SPECIFIED TOLERANCE			All Connectors	
				ANGLES	ANG.	±5°	www.allconnectors.de	
				LINEAR	0.0	±0.25	Tel.: 0349 711 700340	
				SCALE	AS SHOWN	UNIT: mm	info@allconnectors.de	
				DRAWN	Willis	2013/12/09	Tel.: 0349 711 700340	
				CHECKED	Angel	2013/12/09	Tel.: 0349 711 700340	
				APPROVED	Ken	2013/12/09	Kettensortir, St.	
							PRODUCT NO.	123A-32MA0-R01
							FILE NAME	123A-32MA0-R01_D_1
REV.	DESCRIPTION	DATE	REV.	DESCRIPTION	DATE	SIZE	REV.	
1						A4	1.0	

- △ Revise:
- △ Revise:
- △ Revise:

All Connectors

www.allconnectors.de
Tel.: 0349 711 700340
info@allconnectors.de
Tel.: 0349 711 700340
Kettensortir, St.

DRAWN NAME:
M.2 Connector Key M H:3.2mm

PRODUCT NO.: 123A-32MA0-R01

FILE NAME: 123A-32MA0-R01_D_1