

This document is the property of Nan-Yeong Corporation and is delivered on the express condition that it is not to be disclosed, reproduced or used, in whole or in part, for manufacture or sale by anyone other than Nan-Yeong Corporation without its prior consent, and that no right is granted to disclose or to use any information in this document.

CUSTOMER DRAWING

REV.	DESCRIPTION	APPROVED BY	DATE	ECN NO.
A	RELEASE	Fido Weng	03/08/10	
B				
C				
D				

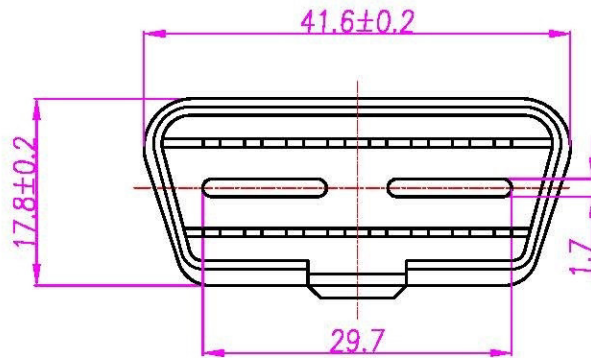
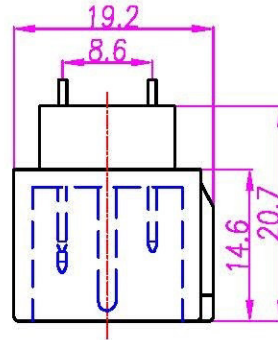
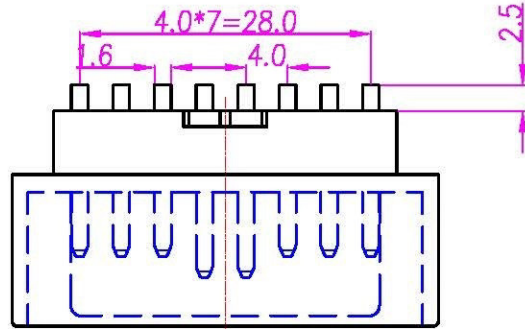
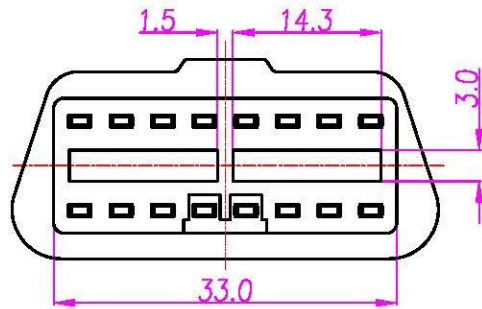

NOTE:

- MATERIAL:
 - 1-1.HOUSING: NYLON 66+15%GF
 - 1-2.CONTACT: BRASS ,t=0.80mm
- PLATING:
 - 2-1.CONTACT:GOLD 30u"
 - 2-2.SOLDER:TIN
 - 2-3.UNDERPLATED NICKEL OVER ALL

DRAWN	APP'D	UNIT	FW	TOLERANCE	SCALE	1:1	ANGULA	±1°	www.allconnectors.de	info@allconnectors.de	TITLE	PART NO.	DWG NO.	VERSION
Emily Suen	Fido Weng	MM		JX ±0.20 JXX ±0.10 JXXX ±0.05 JXXXX ±0.03	1:1				30794 Filzschleife - Germany	K110mm x 17.75	OBD2 16PIN (M) 短版成型式(雙隔版), 端子改短	OBD2-16M1-27	QC4691	A