

This document is the property of Nan-Yeong Corporation and is delivered on the express condition that it is not to be disclosed, reproduced or used, in whole or in part, for manufacture or sale by anyone other than Nan-Yeong Corporation without its prior consent, and that no right is granted to disclose or to use any information in this document.

CUSTOMER DRAWING

REV.	DESCRIPTION	APPROVED BY	DATE	ECN NO.
A	Add DIM	Stewart	Frank	09/10/04"
B				
C				

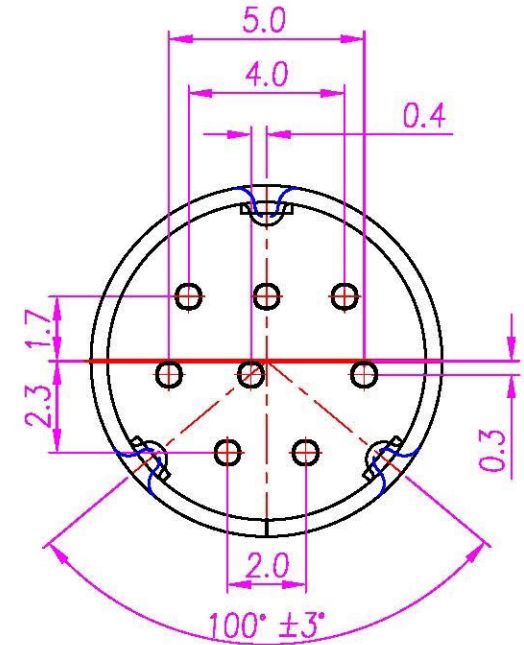
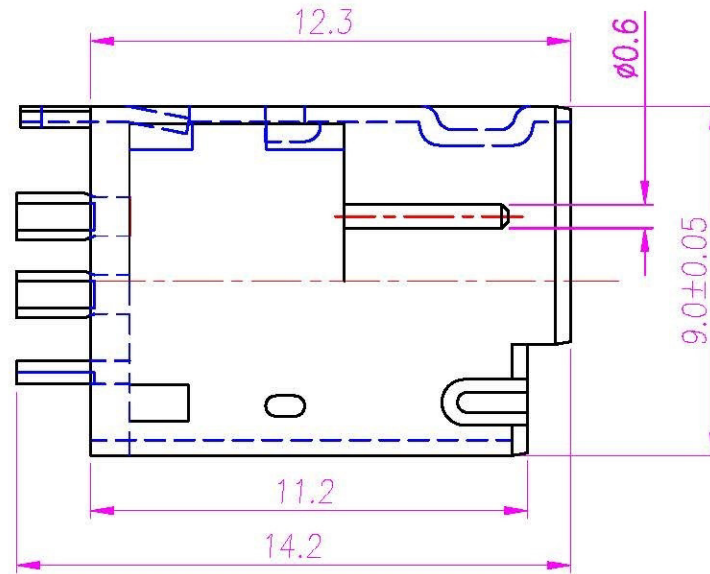
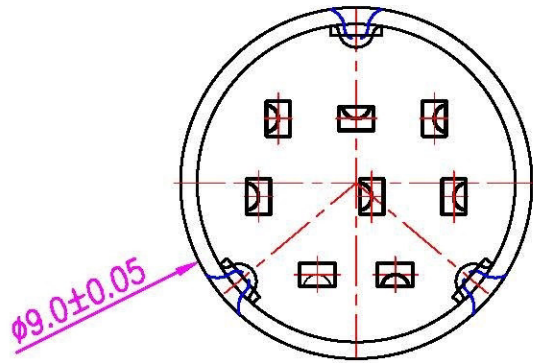

NOTE:

1. MATERIAL :
 - 1-1. HOUSING : PBT UL94V-0 ; COLOR : BLACK
 - 1-2. CONTACT : BRASS
 - 1-3. SHELL : BRASS
2. FINISH :
 - 2-1. CONTACT : SEE TABLE A
 - 2-2. SHELL : NICKEL PLATED.
3. ELETRICAL SPECICATION :
 - 3-1. RATED CURRENT : 2A/DC MAX
 - 3-2. RATED VOLTAGE : 5V/DC MAX
 - 3-3. INSERTION FORCE : 45N (4.5kgf) MAX.
 - 3-4. WITHDRAWAL FORCE : 9N(0.9kg) to 30N(3kg)
4. ENVIRONMENTAL :
 - 4-1. OPERATION TEMPERATURE : -20 ℃~85℃

TABLE A

MD-08M1-17-11	MD 8P杯口(金15u") 成品	金15u"/ GOLD 15u"
MD-08M1-11	MD 8P杯口(表金) 成品	表金 / GOLD FLASH
MD-08M1-10	MD 8P杯口(銀) 成品	銀 30u"/ SILVER 30u"
MD-08M1-03	MD 8P杯口(錫) 成品	錫 60u"/ TIN 60u"
P/N	DESCRIPTION	PLATING

DRAWN	APP'D	UNIT	PR	TOLERANCE	ALL CONNECTORS	TITLE	MINI DIN 8PIN (M) 杯口			SHEET	
CHK'D		SCALE	1:1	X ±0.20 XX ±0.10 XXX ±0.05 XXXX ±0.03 ANGULA ±1°	www.allconnectors.de Tel: 0049 711 400543 70734 Filderstadt Germany	Info@allconnectors.de Fax: 0049 711 400501 Kellernersstr. 25	PART NO.	SEE TABLE A	DWG NO.	QC0018	VERSION A