

NOTE:

1. MATERIAL AND FINISH

1.1. SHELL ASSEMBLY: COPPER ALLOY, OUTER SHELL AND COLLET NUT Cr PLATING, OTHER METALLIC COMPONENTS Ni PLATING

1.2. INSULATOR: PEEK

1.3. CONTACT: COPPER ALLOY, GOLD PLATING

2. RoHS COMPLIANCE

3. CRIMP CONTACT DETAILS SHOWN IN VIEW 1

4. PART NO.

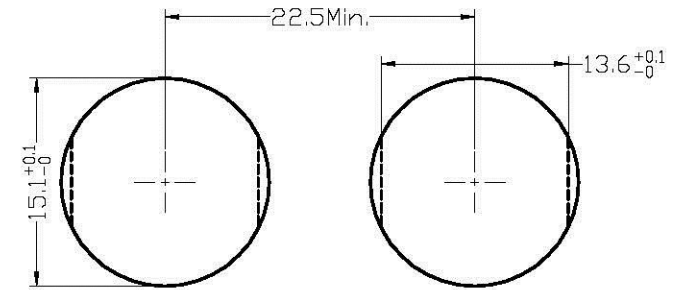

PANEL CUT-OUT

R - F 2 B R * * 0 * 0 0 * 0 0

| |
|------------------|
| CONTACT POS. |
| 02-32=2pin-32pin |

| |
|----------------|
| SHELL MATERIAL |
| 0=Brass |

| CODE | KEY ANGLES |
|------|------------|
| 0 | 0 |
| A | 30° |
| B | 60° |
| " | " |

| No. OF CONTACTS | ØA | L |
|-----------------------|-----|-----|
| 02,03,04,05,06,07, | 0.7 | 3.0 |
| 08,10,12,14,16,18,19, | 0.7 | 3.0 |
| 26,32, | 0.5 | 3.0 |

| CODE | CONTACT TYPE |
|------|-----------------------|
| 2 | Male Solder Contact |
| 4 | Female Solder Contact |
| C | Crimp Male Contact |
| M | Crimp Female Contact |
| 1 | Male Print Contact |
| 3 | Female Print Contact |

| | | | | | |
|-------------------------------------------------------------------------------|--------|----------------------------------------------|----------------------|-------------------------|-------------------------|
| UNITS <input checked="" type="checkbox"/> mm <input type="checkbox"/> INCH | | NAME: SNAP LATCH METAL 2B FIXED SOCKET | | | |
| GENERAL TOLERANCES: (UNLESS SPECIFIED) | | PART NO: R-F2BR**0*00*00 | | TITLE: CUSTOMER DWG. | |
| | mm | INCH | APPD: Seawen 3/15/14 | | DWG NO: 010-0000-B30 |
| 4 PLACE | ± ** | ± ** | CHKD: Annie 3/15/14 | | C |
| 3 PLACE | ± 0.10 | ± ** | DRAWN: Alex 3/15/14 | | SCALE: SHEET: REV.: |
| 2 PLACE | ± 0.30 | ± ** | | | 2.5/1 1/7 X1 |
| 1 PLACE | ± 0.50 | ± ** | | | |
| ANGULAR: | X°± 2° | X°± ** | | | |

| REV. | DESCRIPTION | DATE | APPD |
|------|-------------|---------|--------|
| X1 | NEW RELEASE | 3/15/14 | Seawen |

2B FIXED SOCKET SOLDER CONTACT TYPE VIEW

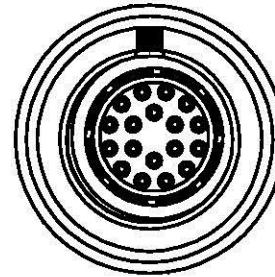
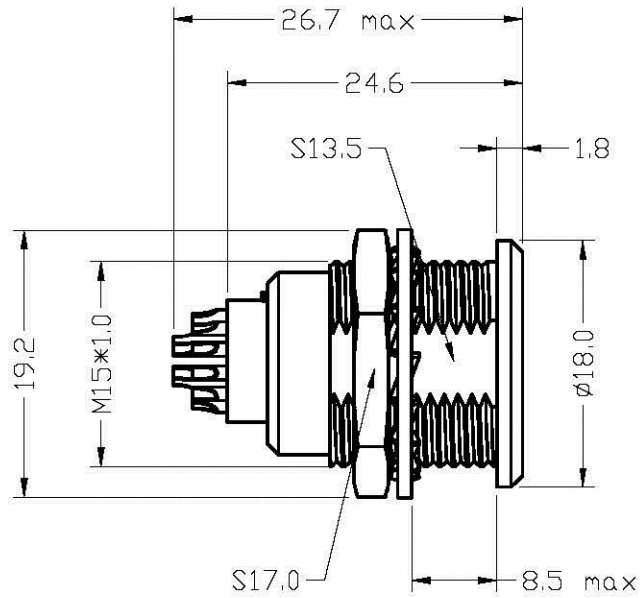

| | | | | | |
|-------------------------------------------------------------------------------|---------|----------------------------------------------|----------------------|-------------------------|------------|
| UNITS <input checked="" type="checkbox"/> mm <input type="checkbox"/> INCH | | NAME: SNAP LATCH METAL 2B FIXED SOCKET | | | |
| GENERAL TOLERANCES: (UNLESS SPECIFIED) | | PART NO: R-F2BR**0*00*00 | | TITLE: CUSTOMER DWG. | |
| | mm | INCH | APPD: Seawen 3/15/14 | DWG NO: 010-0000-B30 | C |
| 4 PLACE | ± **.10 | ± **.004 | CHKD: Annie 3/15/14 | SCALE: 2.5/1 | SHEET: 2/7 |
| 3 PLACE | ± 0.10 | ± **.004 | DRAWN: Alex 3/15/14 | REV: X1 | |
| 2 PLACE | ± 0.30 | ± **.012 | | | |
| 1 PLACE | ± 0.50 | ± **.020 | | | |
| ANGULAR: | X° ± 2° | X° ± **.075 | | | |

| | | | |
|------|-------------|---------|--------|
| X1 | NEW RELEASE | 3/15/14 | Seawen |
| REV. | DESCRIPTION | DATE | APPD |

2B FIXED SOCKET PRINT CONTACT TYPE VIEW

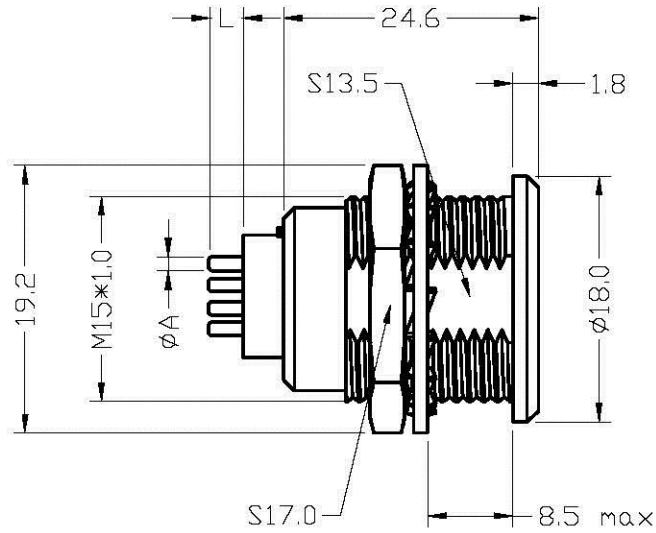

| | | | | | |
|-------------------------------------------------------------------------------|---------|----------------------------------------------|----------------------|-------------------------|------------|
| UNITS <input checked="" type="checkbox"/> mm <input type="checkbox"/> INCH | | NAME: SNAP LATCH METAL 2B FIXED SOCKET | | | |
| GENERAL TOLERANCES: (UNLESS SPECIFIED) | | PART NO: R-F2BR**0*00*00 | | TITLE: CUSTOMER DWG. | |
| | mm | INCH | APPD: Seawen 3/15/14 | DWG NO: 010-0000-B30 | C |
| 4 PLACE | ± **.05 | ± **.002 | CHKD: Annie 3/15/14 | SCALE: 2.5/1 | SHEET: 3/7 |
| 3 PLACE | ± 0.10 | ± **.005 | DRAWN: Alex 3/15/14 | REV: X1 | |
| 2 PLACE | ± 0.30 | ± **.020 | | | |
| 1 PLACE | ± 0.50 | ± **.040 | | | |
| ANGULAR: | X° ± 2° | .X° ± **.05 | | | |

| | | | |
|------|-------------|---------|--------|
| X1 | NEW RELEASE | 3/15/14 | Seawen |
| REV. | DESCRIPTION | DATE | APPD |

2B FIXED SOCKET CRIMP CONTACT TYPE VIEW

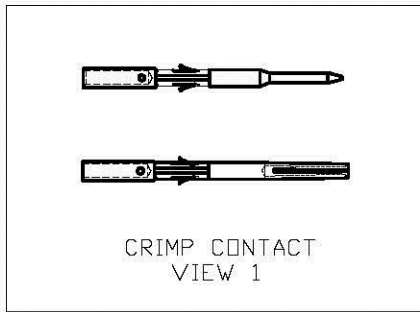
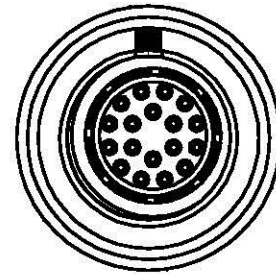
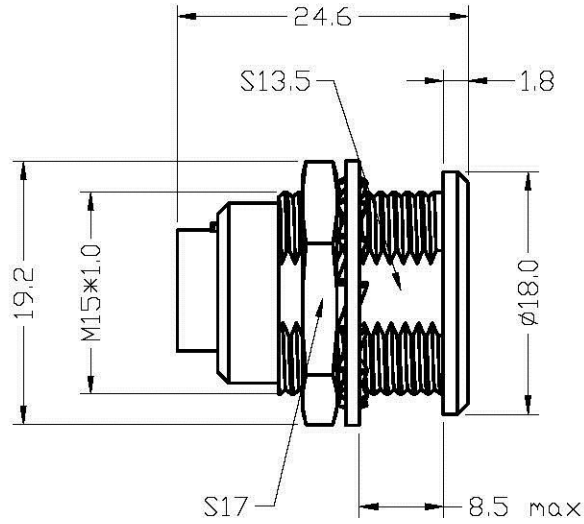

| | | | | | |
|-------------------------------------------------------------------------------|---------|----------------------------------------------|----------------------|---------------------------------------------------------------------------------------|-------------------------|
| UNITS <input checked="" type="checkbox"/> mm <input type="checkbox"/> INCH | | NAME: SNAP LATCH METAL 2B FIXED SOCKET | |  | |
| GENERAL TOLERANCES: (UNLESS SPECIFIED) | | PART NO: R-F2BR**0*00*00 | | TITLE: CUSTOMER DWG. | |
| | mm | INCH | APPD: Seawen 3/15/14 | | DWG NO: 010-0000-B30 |
| 4 PLACE | ± ** | ± ** | CHKD: Annie 3/15/14 | | C |
| 3 PLACE | ± 0.10 | ± ** | DRAWN: Alex 3/15/14 | | |
| 2 PLACE | ± 0.30 | ± ** | | | |
| 1 PLACE | ± 0.50 | ± ** | | | |
| ANGULAR: | X° ± 2° | X° ± ** | | | |
| SCALE: | 2.5/1 | SHEET: | 4/7 | REV.: | X1 |

| | | | |
|------|-------------|---------|--------|
| X1 | NEW RELEASE | 3/15/14 | Seawen |
| REV. | DESCRIPTION | DATE | APPD |

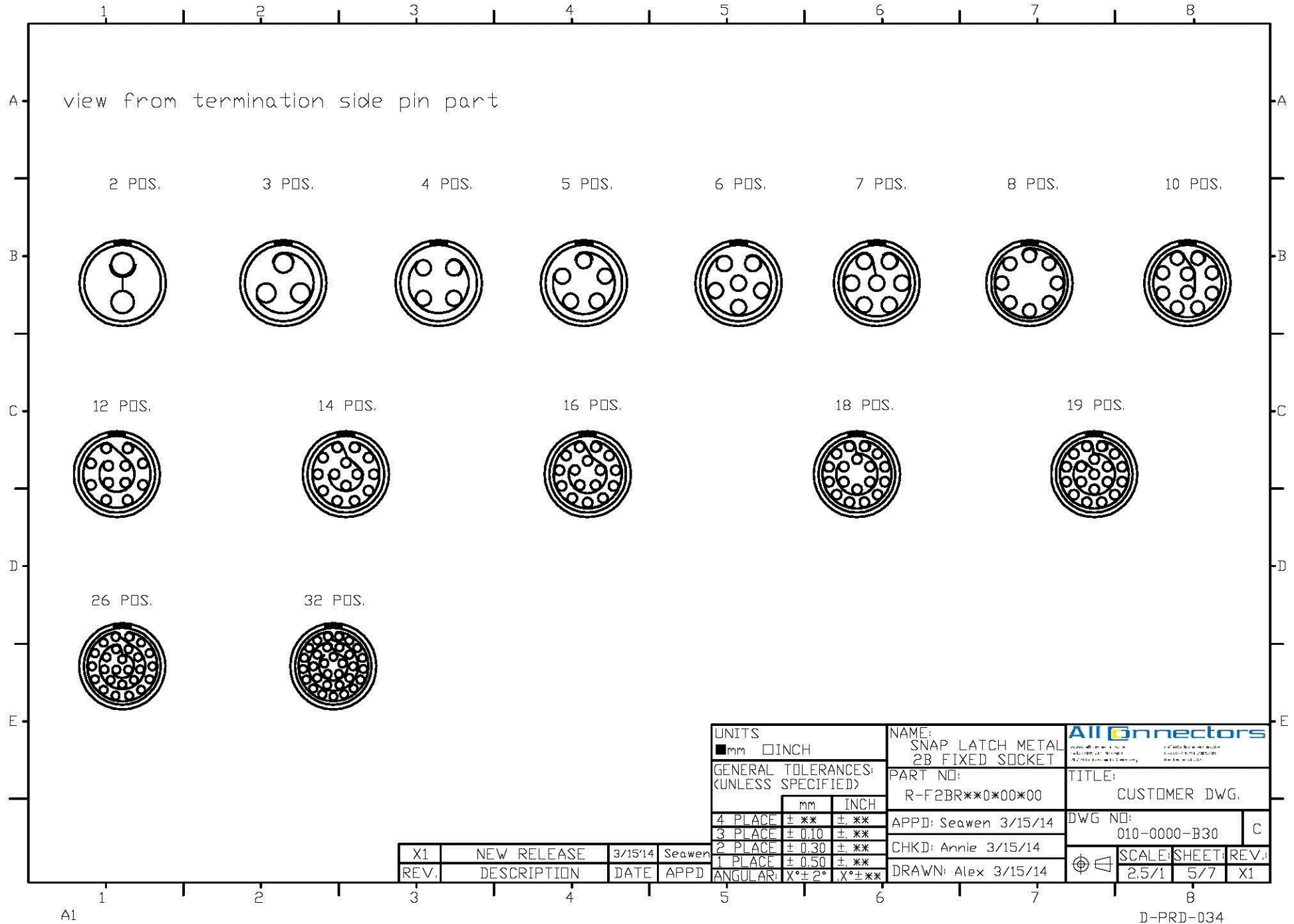

| | | | | | |
|-------------------------------------------------------------------------------|---------|----------------------------------------------|----------------------|-------------------------|------------|
| UNITS <input checked="" type="checkbox"/> mm <input type="checkbox"/> INCH | | NAME: SNAP LATCH METAL 2B FIXED SOCKET | | | |
| GENERAL TOLERANCES: (UNLESS SPECIFIED) | | PART NO: R-F2BR**0*00*00 | | TITLE: CUSTOMER DWG. | |
| | mm | INCH | APPD: Seawen 3/15/14 | DWG NO: 010-0000-B30 | |
| 4 PLACE | ± ** | ± ** | CHKD: Annie 3/15/14 | C | |
| 3 PLACE | ± 0.10 | ± ** | DRAWN: Alex 3/15/14 | SCALE: 2.5/1 | SHEET: 5/7 |
| 2 PLACE | ± 0.30 | ± ** | | REV: X1 | |
| 1 PLACE | ± 0.50 | ± ** | | | |
| ANGULAR: | X° ± 2° | X° ± ** | | | |

| | | | |
|------|-------------|---------|--------|
| X1 | NEW RELEASE | 3/15/14 | Seawen |
| REV. | DESCRIPTION | DATE | APPD |

KEY ANGLES (RECEPTACLE FRONT VIEW):

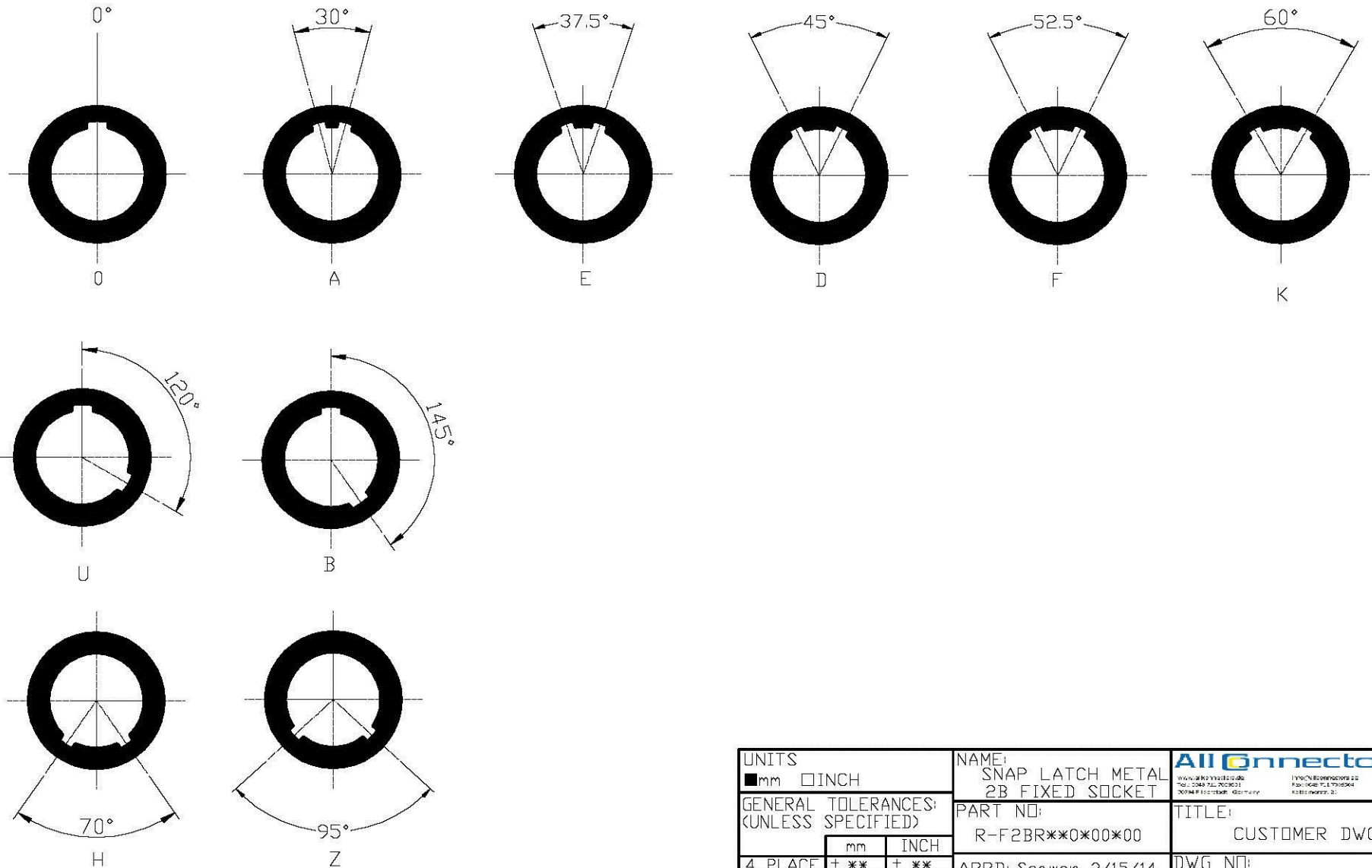

| | | | | | |
|-------------------------------------------|-------------|----------------------------------------------|----------------------|-------------------------------------------------------------------------------------------------------------------------------------------------------------------------------------------------|-------------------------|
| UNITS ■ mm □ INCH | | NAME: SNAP LATCH METAL 2B FIXED SOCKET | |  <small>1790 N. Bismarck Blvd Tel: 2048 711 7028/31 20744 N. Bismarck Blvd, Minn. 55120</small> | |
| GENERAL TOLERANCES: (UNLESS SPECIFIED) | | PART NO: R-F2BR**0*00*00 | | TITLE: CUSTOMER DWG. | |
| | mm | INCH | APPD: Seawen 3/15/14 | | DWG NO: 010-0000-B30 |
| 4 PLACE | ± **.05 | ± **.001 | CHKD: Annie 3/15/14 | | C |
| 3 PLACE | ± 0.10 | ± **.001 | DRAWN: Alex 3/15/14 | | |
| 2 PLACE | ± 0.30 | ± **.001 | | | |
| 1 PLACE | ± 0.50 | ± **.001 | | | |
| ANGULAR: | X° ± 2° | X° ± **.001 | | | |
| REV. | DESCRIPTION | DATE | APPD | SCALE: 2.5/1 | SHEET: 6/7 |
| X1 | NEW RELEASE | 3/15/14 | Seawen | REV.: | X1 |

PCB Drilling Pattern

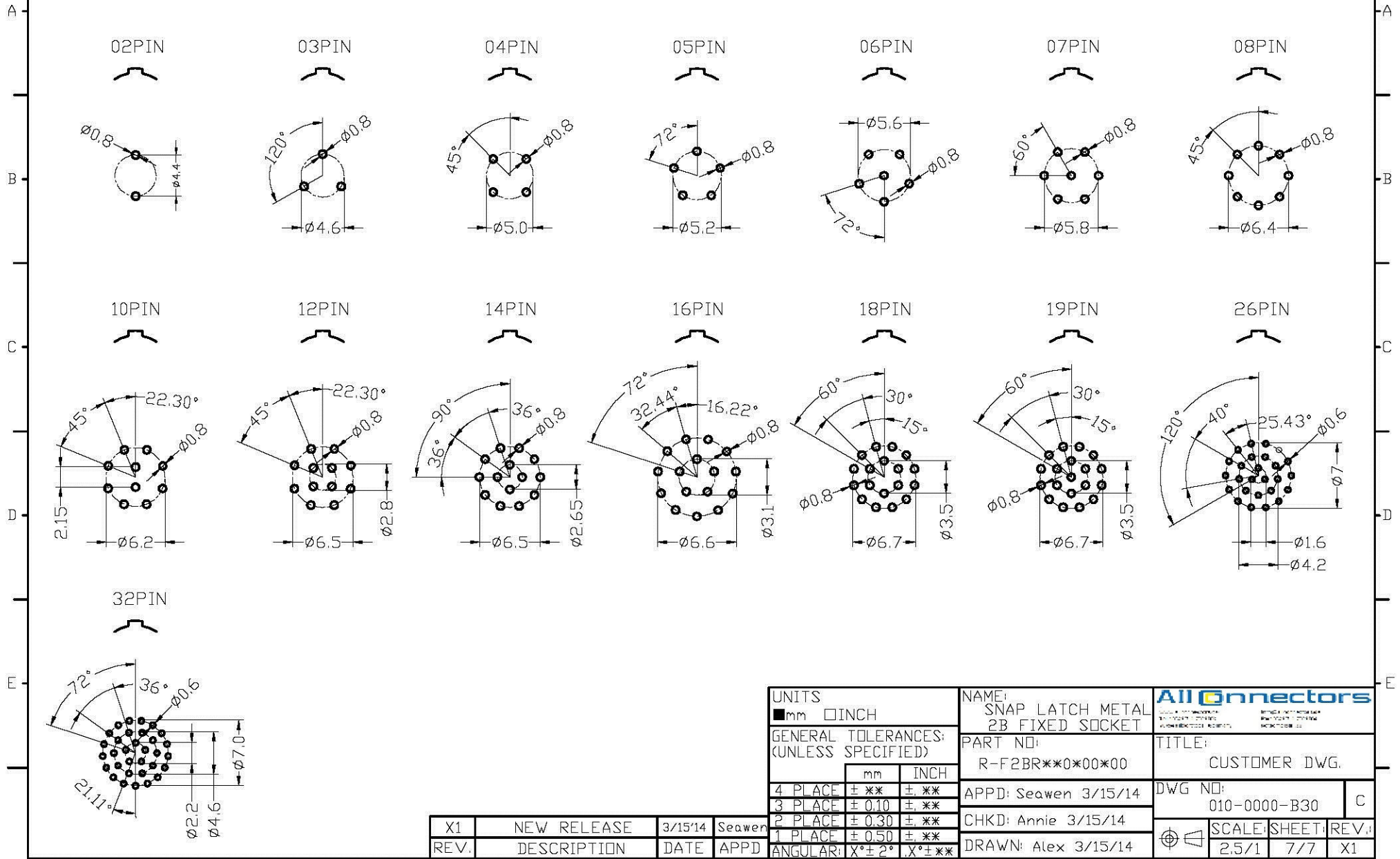

| | | | | | |
|-------------------------------------------------------------------------------|-----------------------|----------------------------------------------|----------------------|------------------------------------|--|
| UNITS <input checked="" type="checkbox"/> mm <input type="checkbox"/> INCH | | NAME: SNAP LATCH METAL 2B FIXED SOCKET | | | |
| GENERAL TOLERANCES: (UNLESS SPECIFIED) | | PART NO: R-F2BR**0*00*00 | | TITLE: CUSTOMER DWG. | |
| | mm | INCH | APPD: Seawen 3/15/14 | DWG NO: 010-0000-B30 | |
| 4 PLACE | $\pm .**$ | $\pm .**$ | CHKD: Annie 3/15/14 | C | |
| 3 PLACE | ± 0.10 | $\pm .**$ | DRAWN: Alex 3/15/14 | SCALE: SHEET: REV: 2.5/1 7/7 X1 | |
| 2 PLACE | ± 0.30 | $\pm .**$ | | | |
| 1 PLACE | ± 0.50 | $\pm .**$ | | | |
| ANGULAR: | $X^\circ \pm 2^\circ$ | $X^\circ \pm **$ | | | |

| | | | |
|------|-------------|---------|--------|
| X1 | NEW RELEASE | 3/15/14 | Seawen |
| REV. | DESCRIPTION | DATE | APPD |