

1 2 3 4 5 6 7 8

NOTE:

1. MATERIAL AND FINISH
SHELL ASSEMBLY: COPPER ALLOY, OUTER SHELL AND COLLECT NUT Cr PLATING, OTHER METALLIC COMPONENTS NI PLATING
INSULATOR: PEEK
CONTACT: COPPER ALLOY, GOLD PLATING OVER NI
2. DURABILITY: 5000 CYCLES
3. PROTECTION INDEX(MATED): IP66/IP68, IP68 ACHIEVED PROVIDING THAT THE CABLE IS PERFECTLY CIRCULAR AND THAT ASSEMBLY PROCESS ENSURES A HIGH INTEGRITY SEAL.
4. HUMIDITY: UP TO 95% AT 60°C
5. TEMPERATURE: -55°C,+200°C
6. ROHS COMPLIANCE
7. PART NO.

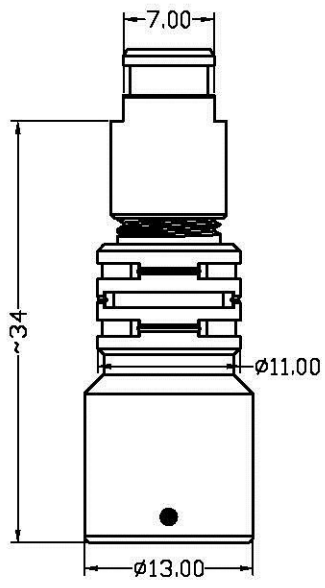

R - F 0 K F * * 0 4 C 1 0 * *

PRODUCT TYPE
F=SNAP LATCH METAL

PRODUCT STYLE
0K=OK STYLE

PRODUCT MODEL
F=FLOATING SOCKET

NUMBER OF CONTACTS
02=02PIN
SEE TABLE

CABLE OD
10=OD: 1.0mm-1.2mm
15=OD: 1.3mm-1.5mm
20=OD: 1.6mm-2.0mm
25=OD: 2.1mm-2.5mm
30=OD: 2.6mm-3.0mm
35=OD: 3.1mm-3.5mm
40=OD: 3.6mm-4.0mm
45=OD: 4.1mm-4.5mm
50=OD: 4.6mm-5.0mm

CONTACT PLATING
4=Au 20u"

POSITIONS	02 PIN	03 PIN	04 PIN	05 PIN	06 PIN	07 PIN	09 PIN
VIEW FROM TERMINATION SIDE PIN PART							

UNITS mm INCH	NAME: SNAP LATCH METAL OK FLOATING SOCKET	All Connectors	
		<small>www.allconnectors.com Tel: 0449 711 70508 2014 Rd Road 11, Seawen Invercailloch, Australia Fax: 0846 711 70604 info@allc.com.au</small>	
GENERAL TOLERANCES: (UNLESS SPECIFIED)	PART NO: R-F0KF**04C10**	TITLE: CUSTOMER DWG.	
	APPD: Seawen 11/06/13	DWG NO: 010-0000-C11	
	CHKD: Peter 11/06/13	C	
	DRAWN: Camby 11/06/13	SCALE: 5/1	SHEET: 1/2
		REV: X1	

REV.	DESCRIPTION	DATE	APPD
X1	NEW RELEASE	11/06/13	Seawen

1 2 3 4 5 6 7 8

NOTE:

1. MATERIAL AND FINISH
SHELL ASSEMBLY: COPPER ALLOY, OUTER SHELL AND COLLECT NUT Cr PLATING, OTHER METALLIC COMPONENTS NI PLATING
INSULATOR: PEEK
CONTACT: COPPER ALLOY, GOLD PLATING OVER NI
2. DURABILITY: 5000 CYCLES
3. PROTECTION INDEX(MATED): IP66/IP68, IP68 ACHIEVED PROVIDING THAT THE CABLE IS PERFECTLY CIRCULAR AND THAT ASSEMBLY PROCESS ENSURES A HIGH INTEGRITY SEAL.
4. HUMIDITY: UP TO 95% AT 60°C
5. TEMPERATURE: -55°C,+200°C
6. ROHS COMPLIANCE
7. PART NO.

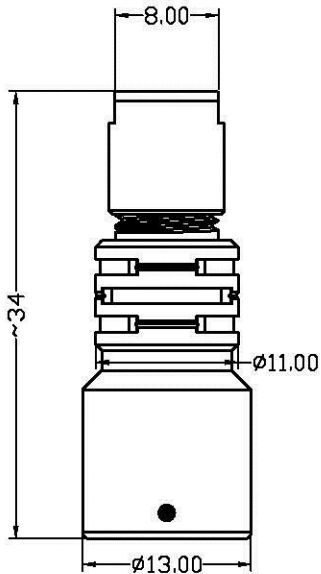

R - F 0 K F * * 0 4 C 2 0 * *

PRODUCT TYPE
F=SNAP LATCH METAL

PRODUCT STYLE
0K=0K STYLE

PRODUCT MODEL
F=FLOATING SOCKET

NUMBER OF CONTACTS
02=02PIN
SEE TABLE

CABLE OD
10=OD: 1.0mm-1.2mm
15=OD: 1.3mm-1.5mm
20=OD: 1.6mm-2.0mm
25=OD: 2.1mm-2.5mm
30=OD: 2.6mm-3.0mm
35=OD: 3.1mm-3.5mm
40=OD: 3.6mm-4.0mm
45=OD: 4.1mm-4.5mm
50=OD: 4.6mm-5.0mm

CONTACT PLATING
4=Au 20u"

POSITIONS	02 PIN	03 PIN	04 PIN	05 PIN	06 PIN	07 PIN	09 PIN
VIEW FROM TERMINATION SIDE PIN PART							

UNITS
 mm INCH

GENERAL TOLERANCES:
(UNLESS SPECIFIED)

	mm	INCH
4 PLACE	±.***	±.***
3 PLACE	±0.30	±.***
2 PLACE	±0.50	±.***
1 PLACE	±0.80	±.***
ANGULAR	X°±2°	X°±***

NAME:
SNAP LATCH METAL
OK FLOATING SOCKET

PART NO:
R-F0KF**04C20**

APPD: Seawen 11/06/13

CHKD: Peter 11/06/13

DRAWN: Camby 11/06/13

All Connectors
INDUSTRIAL CONNECTORS
 TEL: +86 21 20065030
 100188 Wujiaochang Road, Songjiang District, Shanghai 201600, P.R. China

TITLE:
CUSTOMER DWG.

DWG NO:
010-0000-C11

SCALE: SHEET: REV:
5/1 2/2 X1

REV.	DESCRIPTION	DATE	APPD
X1	NEW RELEASE	11/06/13	Seawen