

NO	DESCRIPTION	MATERIAL	Q'TY	FINISH	REMARK
1	BODY 1	BRASS	1	NICKEL	B-TNC0476-N
2	INSULATION	TEFLON	1	TEFLON	I-0231T
3	BODY 2	BRASS	1	GOLD	B-TNC0013-N
4	PIN	BRASS	1	NICKEL	P-TNC0054-G
5	RONG	BRASS	1	NICKEL	R-0007-N

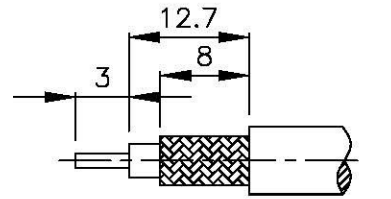

(Recommended Stripping Dimension)

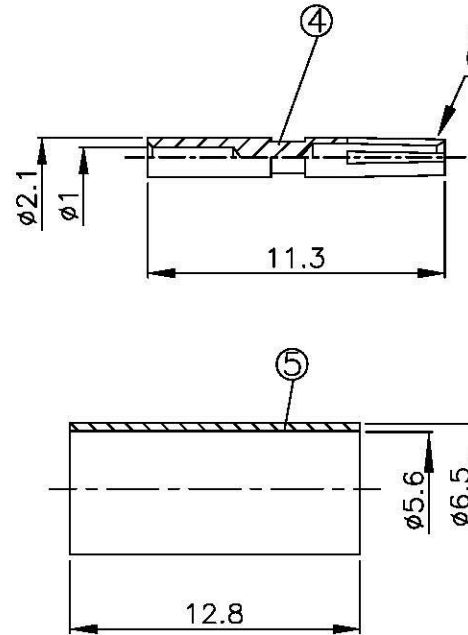
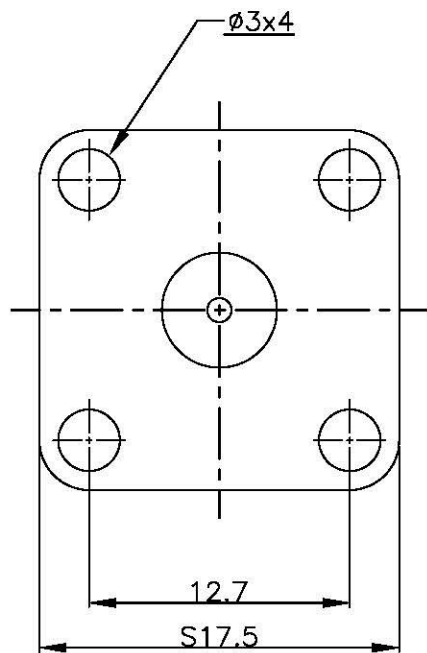
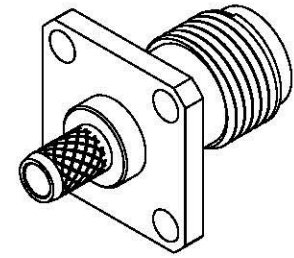

PIN CHUCK  
0.3x4x4 GROOVE

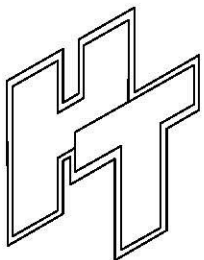
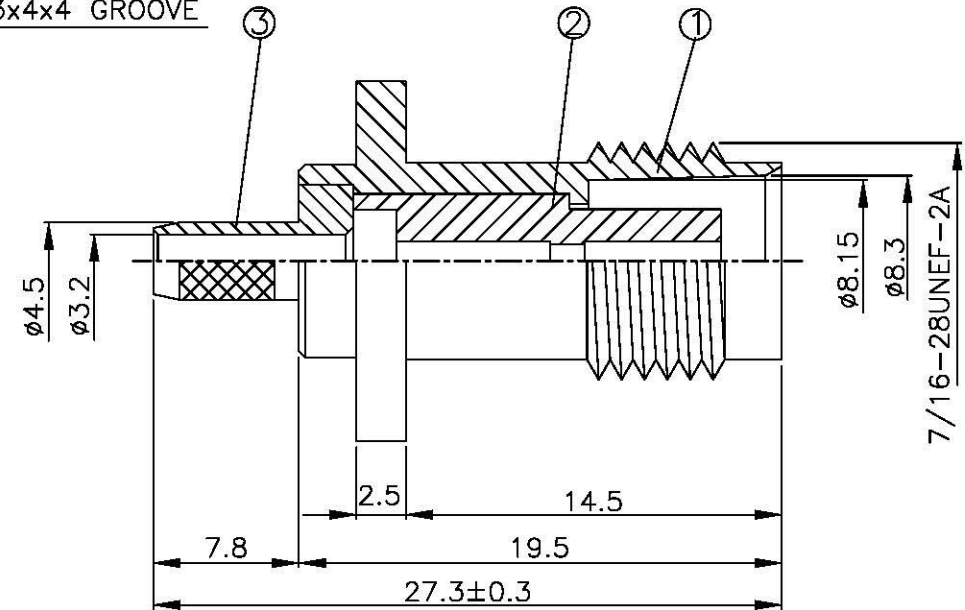

**All Connectors**

www.allconnectors.de  
Tel.: 0049 711 7009008  
info@allconnectors.de  
Fax: 0049 711 7009004  
Kettelerstr. 20

TITLE TNC PANEL FEMALE CRIMP  
FOR RG 58/U

PART NO. TNC-23F-TGN

DRAWING NO. TNC 23F TGN

DRAWN MARY DATE 96.07.11

CHECKED 蘇志欣 DATE

Q.A. 蘇姿潔 DATE

APPROVAL 徐燦霖 DATE

REVISION DATE

DIMENSIONS ARE IN MILLIMETERS

UNLESS OTHERWISE SPECIFIED  
TOLERANCE

0.5-5=±0.2	120-315=±1
5-30=±0.4	315-1000=±1.6
30-120=±0.6	1000-2000=±2.4

SCALE 4:1 SIZE A

REVISION

DESCRIPTION	ENGINEER