

NO	DESCRIPTION	MATERIAL	Q'TY	FINISH	REMARK
1	BODY	BRASS	1	NICKEL	B-TNC0926-N
2	INSULATION	TEFLON	1	TEFLON	I-0452T
3	BODY	BRASS	1	NICKEL	B-TNC0117-N
4	GASKET	SI RUBBER	1	RUBBER	RU-0006
5	WASHER	BRASS	1	NICKEL	W-0001-N
6	NUT	BRASS	1	NICKEL	N-0003-N
7	PIN	BRASS	1	GOLD	P-TNC0652-G
8	PIN	BRASS	1	GOLD	P-FME0505-G
9	INSULATION	TEFLON	1	TEFLON	I-0256T
10	BODY	BRASS	1	GOLD	B-SMA0902-G

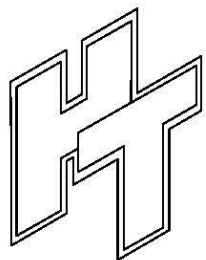
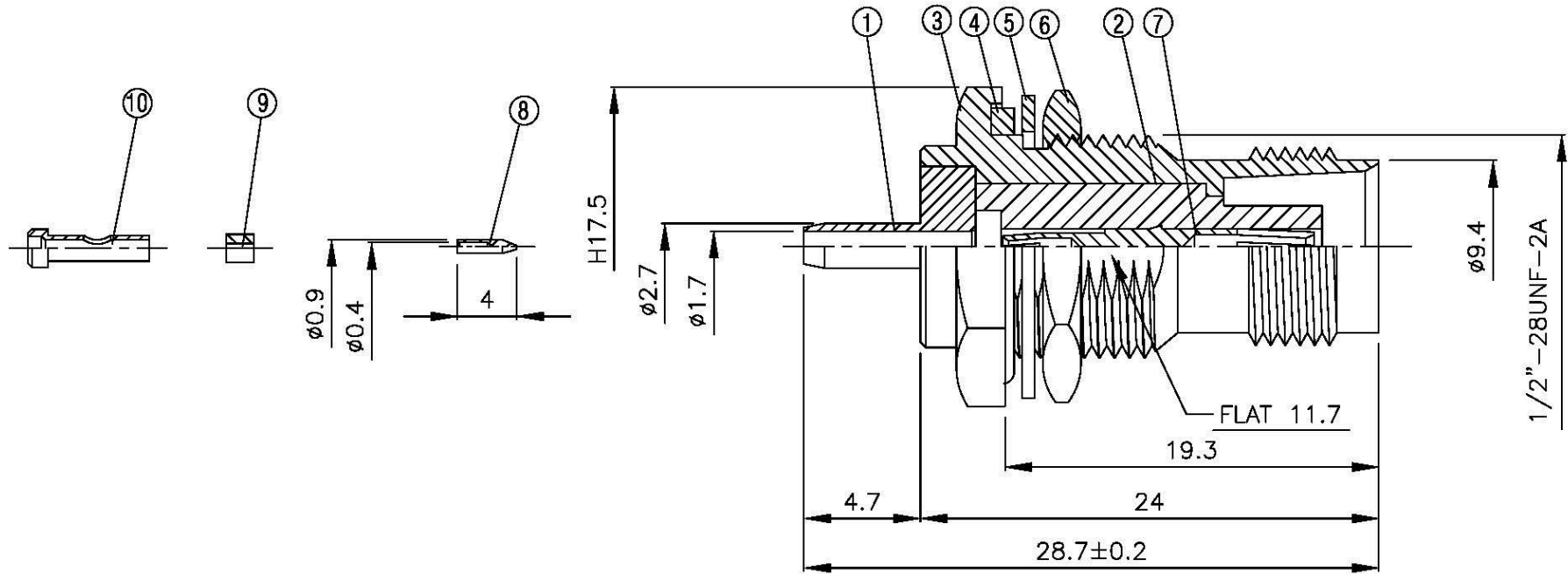
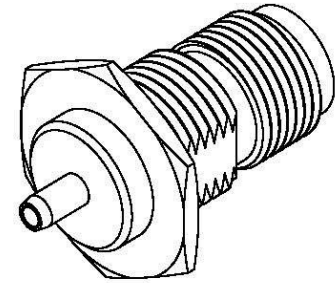
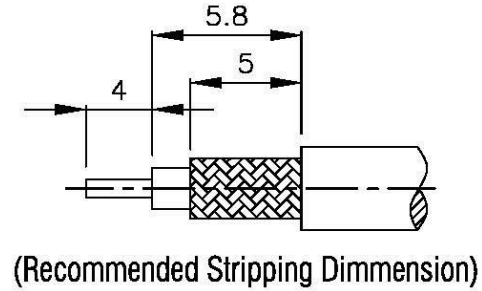

All Connectors

www.allconnectors.de
TEL: 0049 211 2009503
20299 Ulmenbaust - Germany

Info@allconnectors.de
Fax: 0049 211 2009504
Kontakt@allconnectors.de

TITLE FEMALE CRIMP FOR
HRS-1.3

PART NO. TNC-07U-TGN

DRAWING NO. TNC 07U TGN

DRAWN MARY DATE 96.03.15

CHECKED 蘇姿潔 DATE

Q.A. 馮健華 DATE

APPROVAL 徐燦霖 DATE

REVISION DATE

DIMENSIONS ARE IN MILLIMETERS

UNLESS OTHERWISE SPECIFIED
TOLERANCE

0.5-5=±0.2 120-315=±1

5-30=±0.4 315-1000=±1.6

30-120±0.6 1000-2000=±2.4

SCALE 4:1 SIZE A

REVISION

DESCRIPTION ENGINEER