

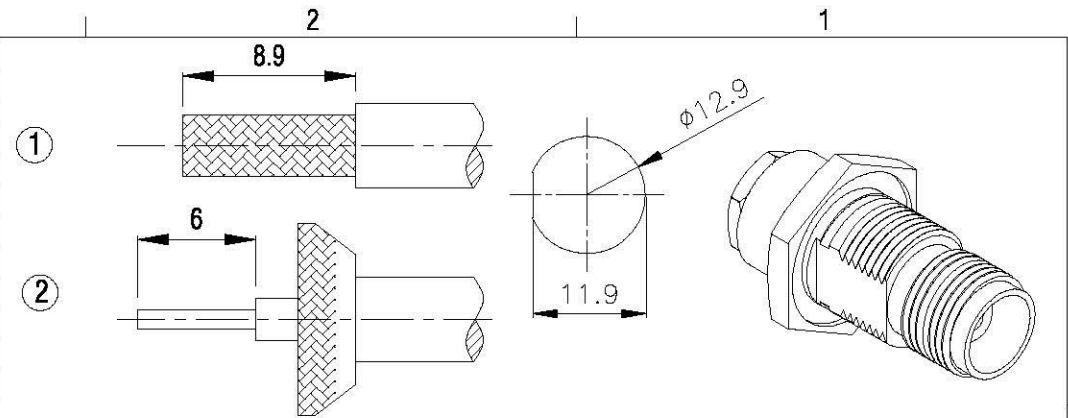

| 4  |             |          |      | 3      |             |
|----|-------------|----------|------|--------|-------------|
| NO | DESCRIPTION | MATERIAL | Q'TY | FINISH | REMARK      |
| 1  | NUT         | BRASS    | 1    | NICKEL | N-0067-N    |
| 2  | BODY 1      | BRASS    | 1    | NICKEL | B-TNC1406-N |
| 3  | WASHER      | BRASS    | 1    | NICKEL | W-0083-N    |
| 4  | GASKET      | RUBBER   | 1    | RUBBER | RU-0052     |
| 5  | WASHER      | BRASS    | 1    | NICKEL | W-0085-N    |
| 6  | INSULATION  | TEFLON   | 1    | TEFLON | I-0448T     |
| 7  | WASHER      | BRASS    | 1    | NICKEL | W-0001-N    |
| 8  | NUT         | BRASS    | 1    | NICKEL | N-0003-N    |
| 9  | GASKET      | RUBBER   | 1    | RUBBER | RU-0006     |
| 10 | PIN         | BRASS    | 1    | GOLD   | P-TNC0019-G |
| 11 | WASHER      | BRASS    | 1    | NICKEL | W-0089-N    |

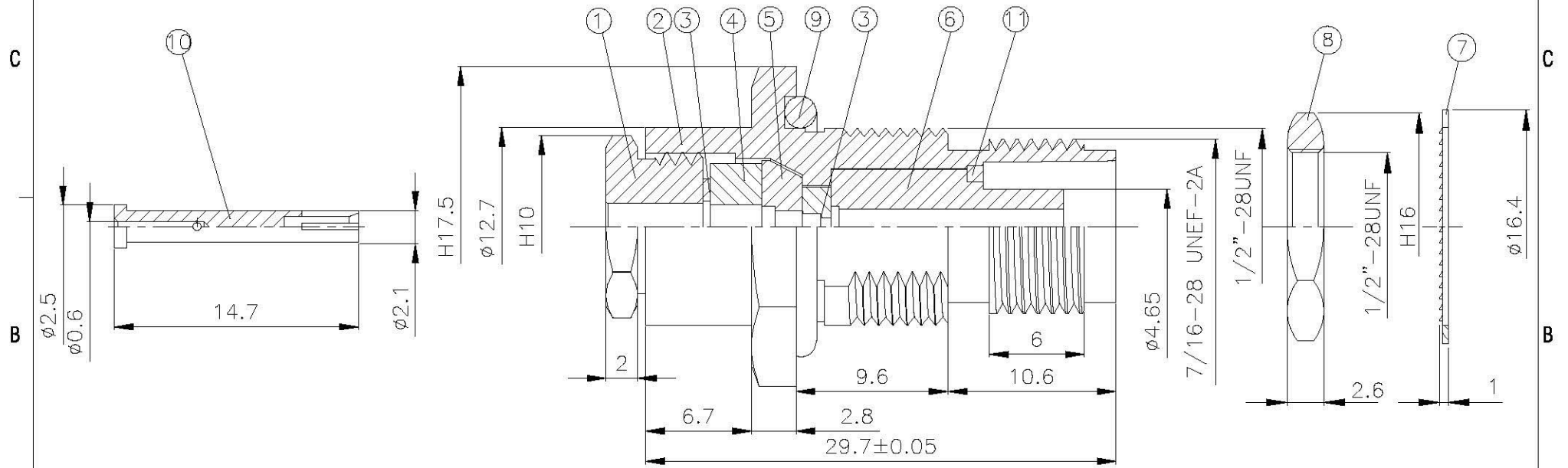

(Recommended Stripping Dimension)

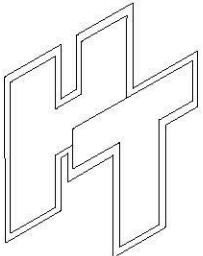

|   |   |   |                               |  |   |             |          |
|---|---|---|-------------------------------|--|---|-------------|----------|
|  |          | DRAWN MARY<br>DATE 96.06.08   | DIMENSIONS ARE IN MILLIMETERS |  | REVISION                                      |             |          |
|   | <small>www.allconnectors.de<br/>Tel.: 0049 711 3009501<br/>20751 Flörsdorf, Germany</small> | <small>info@allconnectors.de<br/>Fax: 0049 711 3009504<br/>Kellerstraße, 25</small> | CHECKED 蘇姿潔<br>DATE           | UNLESS OTHERWISE SPECIFIED<br>TOLERANCES |   | DESCRIPTION | ENGINEER |
|   | <b>TITLE TNC BULKHADE FEMALE CLAMP FOR RG-316/U</b>   |   | Q.A. 馮健華<br>DATE              | 0.5-5=±0.2<br>5-30=±0.4<br>30-120=±0.6   | 120-315=±1<br>315-1000=±1.6<br>1000-2000=±2.4 |             |          |
|   | PART NO. <b>TNC-02LV1-TGN</b>   |   | APPROVAL 徐燦霖<br>DATE          | SCALE 4:1                                | SIZE A  |             |          |
| DRAWING NO. <b>TNC 02LV1 TGN</b>  |   | REVISION<br>DATE  |                               |  |   |             |          |

4

3

2

1