

NO	DESCRIPTION	MATERIAL	Q'TY	FINISH	REMARK
1	WAHER	BRASS	1	GOLD	W-0015-G
2	BODY	BRASS	1	NICKEL	B-SUMA1631-N
3	INSULATION	TEFLON	1	TEFLON	I-0723T
4	PIN	BE CU	1	GOLD	P-SUMA1088-G-4

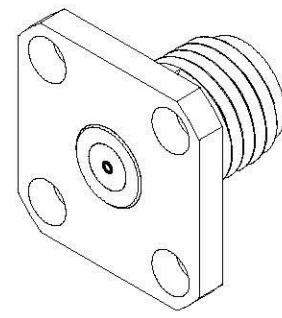

PIN CHUCK
0.2X2X2 GROOVE

ACCEPT 0.5 MM PIN

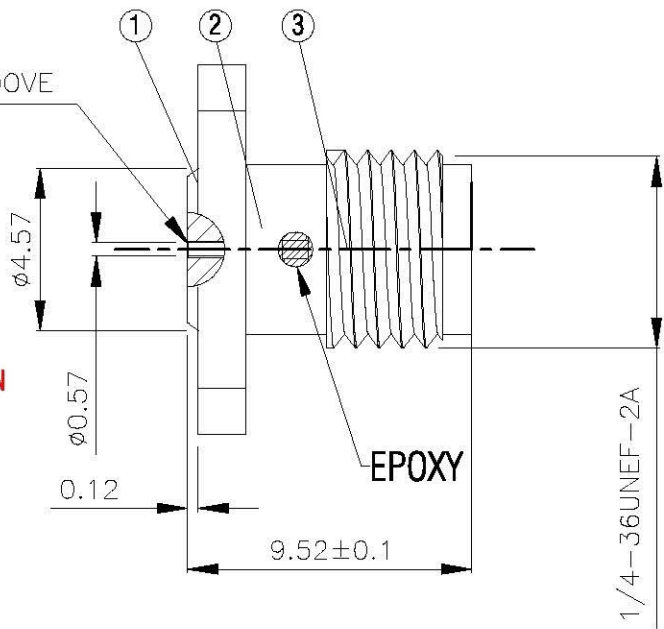

∅2.6X4

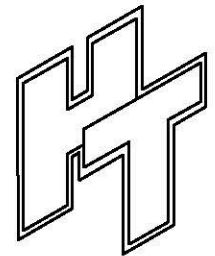
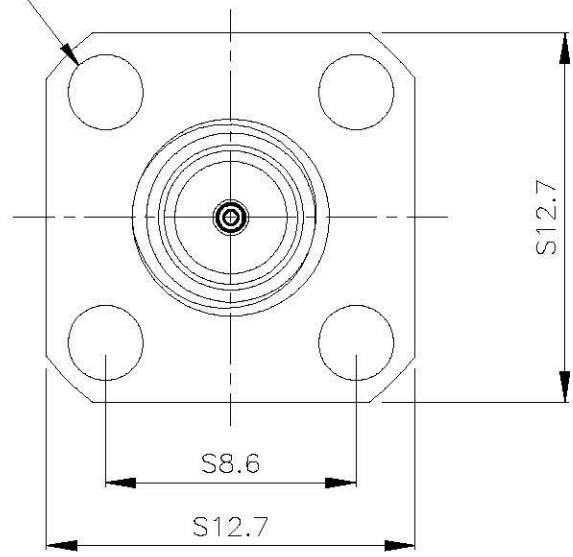

All Connectors
www.allconnectors.de
Tel.: 0049 711 7009503
info@allconnectors.de
Fax: 0049 711 7009504
Kettnerstr. 25

TITLE SUPER SMA FEMALE
LAUNCHERS WITH TRANSITION PINS

PART NO. SUSMA-07V4-TGSUS-4

DRAWING NO. SUSMA-07V4-TGSUS-4

DRAWN 蘇姿潔

CHECKED 蘇志欣

Q.A. 莊千慧

APPROVAL 徐燦霖

REVISION

DATE 99.12.01

DATE 99.12.01

DATE

DATE

DATE

DIMENSIONS ARE IN MILLIMETERS

UNLESS OTHERWISE SPECIFIED TOLERANCE

0.5-5=±0.2 120-315=±1

5-30=±0.4 315-1000=±1.6

30-120=±0.6 1000-2000=±2.4

SCALE 4:1 **SIZE** A

REVISION	
DESCRIPTION	ENGINEER