

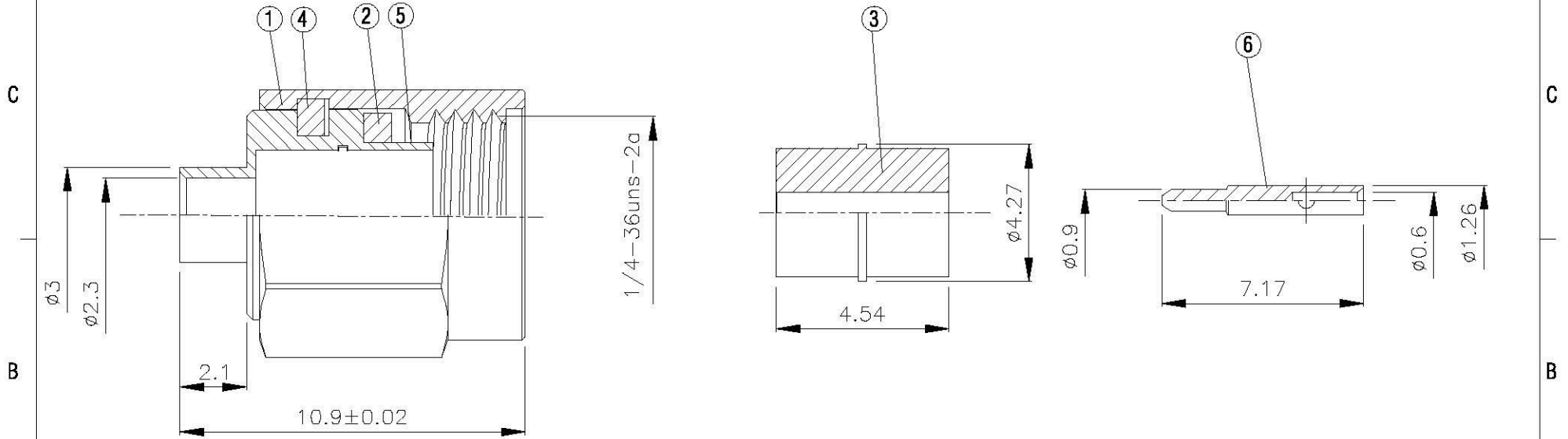

NO	DESCRIPTION	MATERIAL	Q'TY	FINISH	REMARK
1	SHELL	SUS303	1	NICKEL	B-SMA0043-SUS
2	GASKET	SI RUBBER	1	RUBBER	RU-0008
3	INSULATION	TEFLON	1	TEFLON	I-0727T
4	WASHER	SUS303	1	GOLD	W-0012
5	BODY	BRASS	1	GOLD	B-SUMA1635-G
6	PIN	BRASS	1	GOLD	P-SMA1092-G

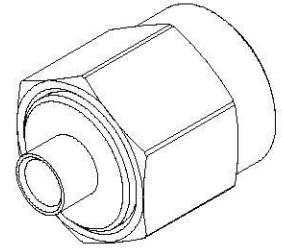
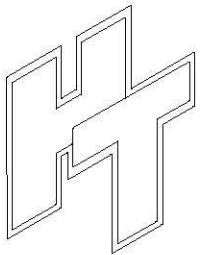

			DRAWN	MARY	DATE	96.03.28		DIMENSIONS ARE IN MILLIMETERS		REVISION	
	<small>www.allconnectors.de TEL: 0249 711 7009105 70794 Heilbronn, Germany</small>		<small>info@allconnectors.de Fax: 0249 711 7009104 Kollmannstr. 2b</small>		CHECKED	蘇姿潔	DATE	UNLESS OTHERWISE SPECIFIED TOLERANCE		DESCRIPTION	ENGINEER
	TITLE		SMA MALE SOLDER FOR RG405 (.085)		Q.A.	馮健華	DATE	0.5-5=±0.2 120-315=±1			
	PART NO.		SUMA-03V1-TGSUS		APPROVAL	徐燦霖	DATE	5-30=±0.4 315-1000=±1.6			
	DRAWING NO.		SUMA 03V1 TGSUS		REVISION		DATE	30-120=±0.6 1000-2000=±2.4			
							SCALE	4:1	SIZE	A	

4

3

2

1

A

A