

NO	DESCRIPTION	MATERIAL	Q'TY	FINISH	REMARK
1	BODY 1	BRASS	1	GOLD	B-SSMC0894-G
2	INSULATION 1	TEFLON	1	TEFLON	I-0431T
3	PIN	BE CU	1	GOLD	P-SSMB0624-G
4	BODY 2	BRASS	1	GOLD	B-SSMC1026-G
5	INSULATION 2	TEFLON	1	TEFLON	I-0113T
6	WASHER	BRASS	1	GOLD	W-0017-G
7	WASHER	BRASS	1	GOLD	W-0060-G
8	NUT	BRASS	1	GOLD	N-0034-G

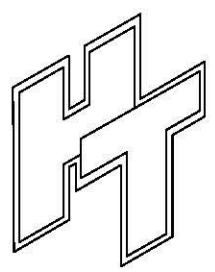
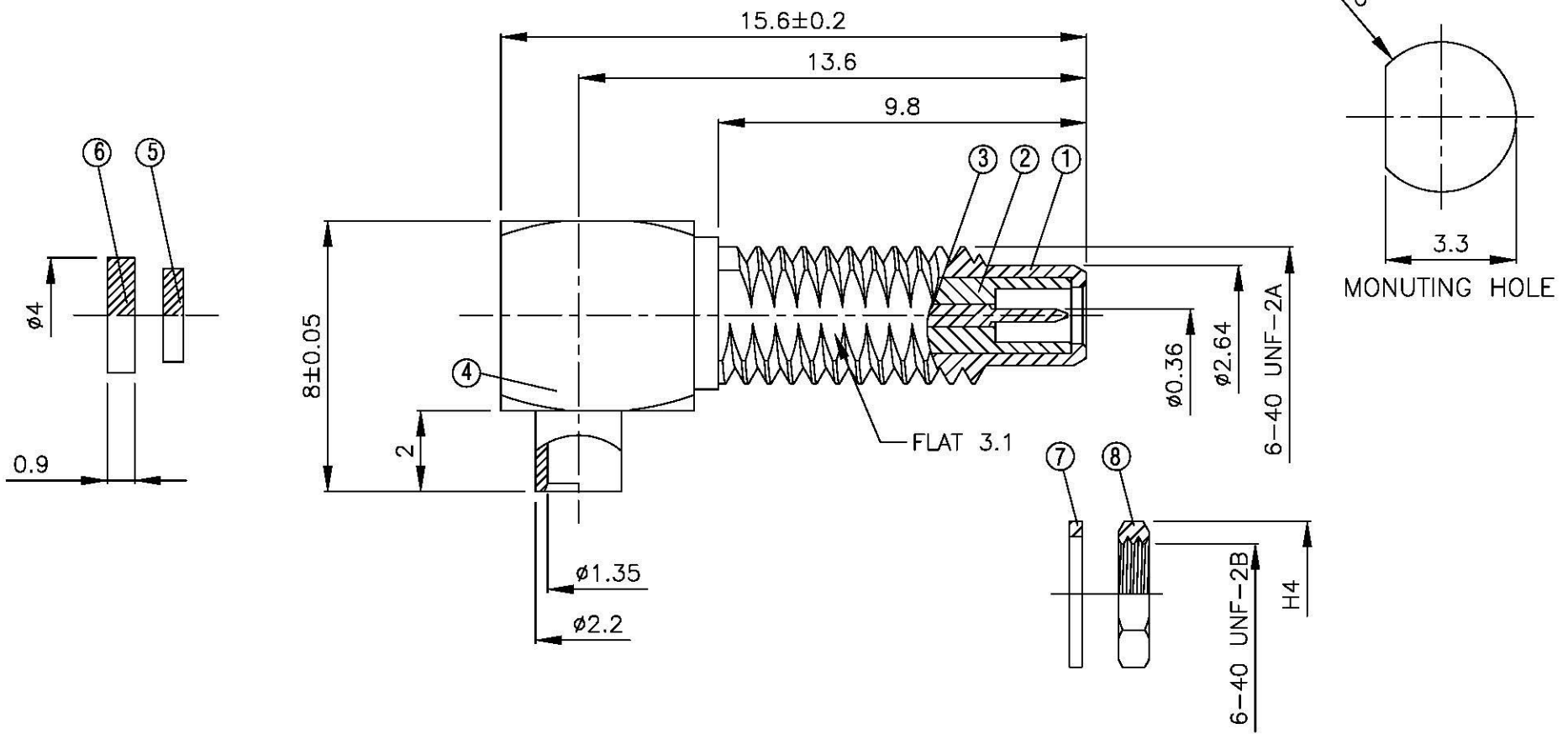
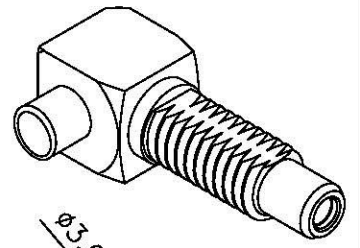
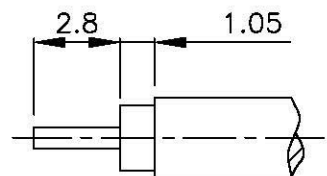

**All Connectors**  
 www.allconnectors.de info@allconnectors.de  
 Tel: +49 4308 213 4000 Fax: +49 4308 213 4000  
 22488 Hildesheim - Germany Betriebsstr. 25

TITLE SSMC MALE ANGLE SOLDER FOR M17/151(.047")

PART NO. SSMC-09V3-TGG

DRAWING NO. SSMC-09V3-TGG

DRAWN MARY DATE 94.03.10

CHECKED 沈佳德 DATE 94.03.10

Q.A. 蘇姿潔 DATE

APPROVA 徐燦霖 DATE

REVISION DATE

DIMENSIONS ARE IN MILLIMETERS

UNLESS OTHERWISE SPECIFIED TOLERANCE

XX = ±0.05  
 X.X = ±0.1  
 X = ±2  
 ANGLE = ±2°

SCALE 4:1 SIZE A

REVISION	
DESCRIPTION	ENGINEER