

NO	DESCRIPTION	MATERIAL	Q'TY	FINISH	REMARK
1	BODY 1	BRASS	1	GOLD	B-SSMC0894-G
2	INSULATION 1	TEFLON	1	TEFLON	I-0431T
3	PIN	BE CU	1	GOLD	P-SSMB0624-G
4	BODY 2	BRASS	1	GOLD	B-SSMC1025-G
5	INSULATION 2	TEFLON	1	TEFLON	I-0113T
6	WASHER	BRASS	1	GOLD	W-0017-G
7	WASHER	BRASS	1	GOLD	W-0060-G
8	NUT	BRASS	1	GOLD	N-0034-G

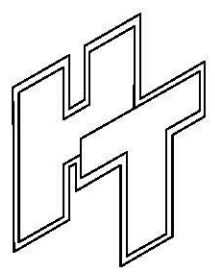
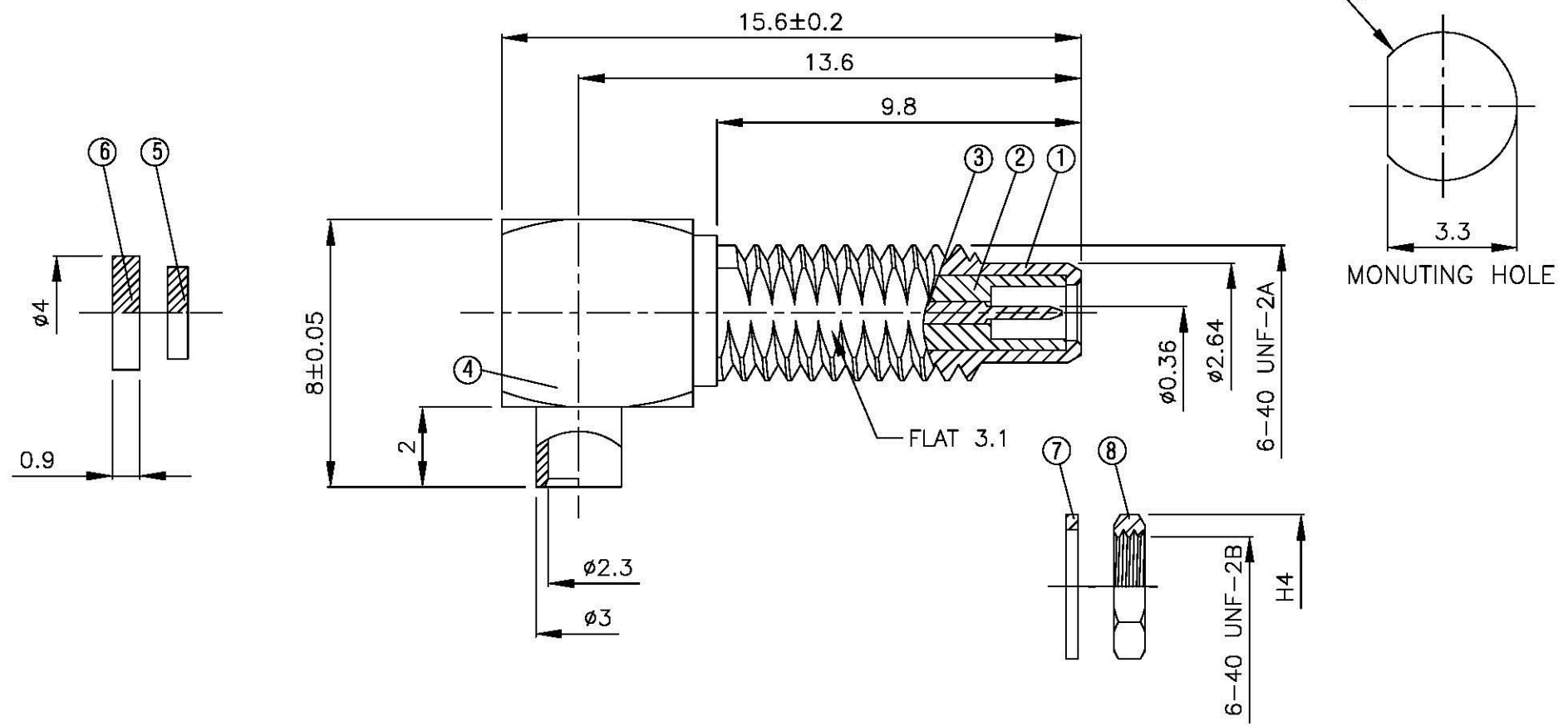
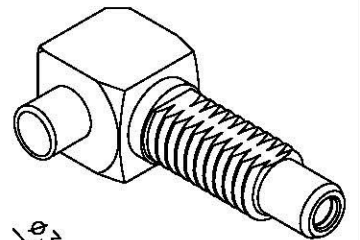
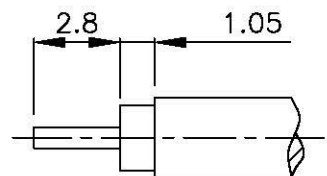

All Connectors
 www.allconnectors.de
 Tel.: 0049 711 7002503
 70794 Filderstadt - Germany
 info@allconnectors.de
 Fax: 0049 711 7002504
 Kettnerstr. 25

TITLE SSMC MALE ANGLE SOLDER FOR RG 405(.085")

PART NO. SSMC-09V1-TGG

DRAWING NO. SSMC-09V1-TGG

DRAWN MARY DATE 94.03.10
 CHECKED 沈佳德 DATE 94.03.10
 Q.A. 蘇姿潔 DATE
 APPROVA 徐燦霖 DATE
 REVISION DATE

DIMENSIONS ARE IN MILLIMETERS

UNLESS OTHERWISE SPECIFIED TOLERANCE

XX= ±0.05
 X.X= ±0.1
 X= ±2
 ANGLE= ±2°

SCALE 4:1 SIZE A

REVISION	
DESCRIPTION	ENGINEER