

NO	DESCRIPTION	MATERIAL	Q'TY	FINISH	REMARK
1	BODY 1	BRASS	1	GOLD	B-SSMB0247-G
2	INSULATION 1	TEFLON	1	TEFLON	I-0051T
3	PIN	PH.BRONZE	1	GOLD	P-SSMC0510-G
4	INSULATION 2	TEFLON	1	TEFLON	I-0350T
5	BODY 2	BRASS	1	GOLD	B-SSMC0722-G
6	WASHER	BRASS	1	GOLD	W-0060-G
7	NUT	BRASS	1	GOLD	N-0034-G
8	RING	BRASS	1	GOLD	R-0033-G

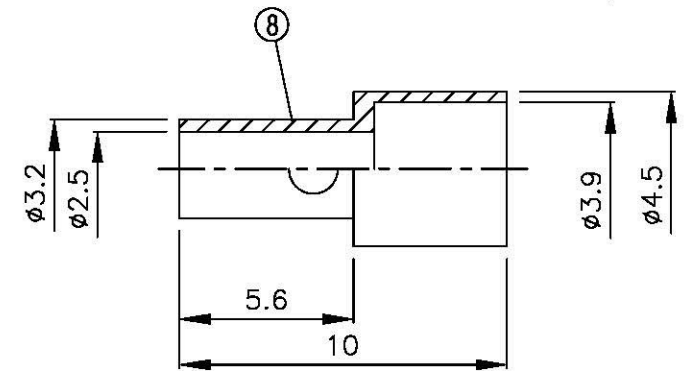
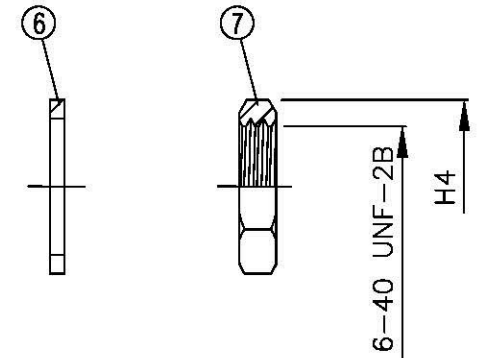
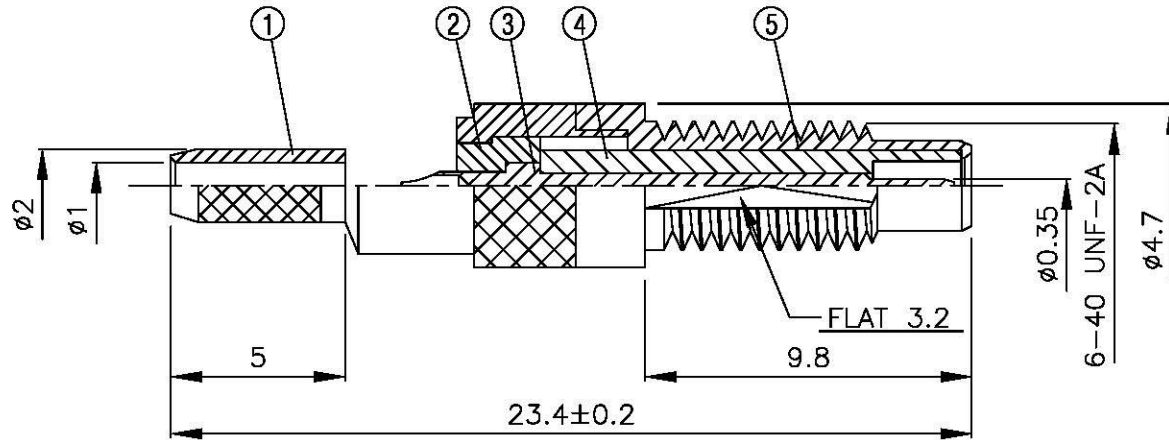
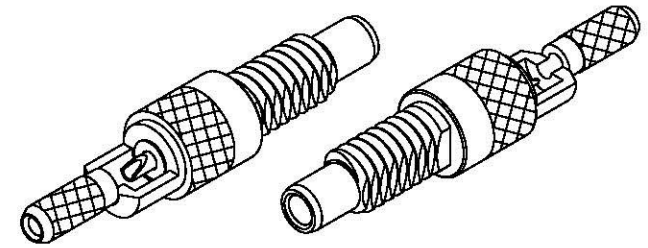

		DRAWN	MARY	DATE	96.07.09	DIMENSIONS ARE IN MILLIMETERS		REVISION				
	<small>www.allconnectors.de info@allconnectors.de 70794 Fellensfeld - Germany</small>	<small>info@allconnectors.de 70794 Fellensfeld - Germany</small>	CHECKED	蘇志欣	DATE						UNLESS OTHERWISE SPECIFIED TOLERANCE	
	TITLE		Q.A.	蘇姿潔	DATE		0.5-5=±0.2	120-315=±1				
	PART NO.		APPROVAL	徐燦霖	DATE		5-30=±0.4	315-1000=±1.6				
	DRAWING NO.		REVISION		DATE		30-120±0.6	1000-2000=±2.4				
						SCALE	4:1	SIZE	A			