

NO	DESCRIPTION	MATERIAL	Q'TY	FINISH	REMARK
1	BODY 1	BRASS	1	GOLD	B-SSMB0241-G
2	INSULATION 1	TEFLON	1	TEFLON	I-0051T
3	PIN	PH.BRONZE	1	GOLD	P-SSMC0510-G
4	INSULATION 2	TEFLON	1	TEFLON	I-0350T
5	BODY 2	BRASS	1	GOLD	B-SSMC0722-G
6	WASHER	BRASS	1	GOLD	W-0060-G
7	NUT	BRASS	1	GOLD	N-0034-G
8	RING	BRASS	1	GOLD	R-0032-G

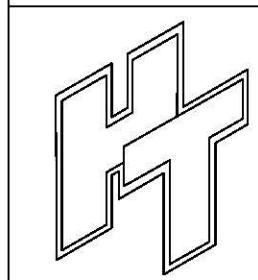
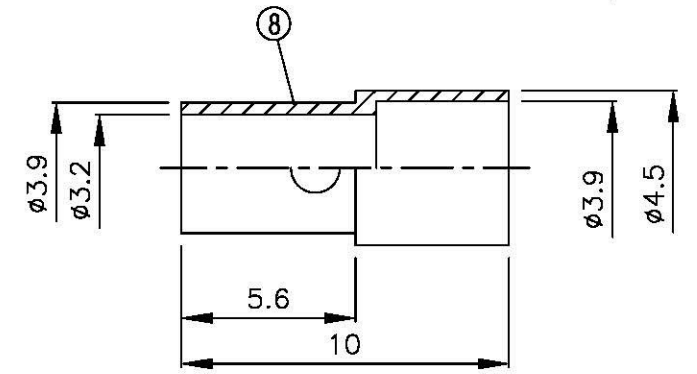
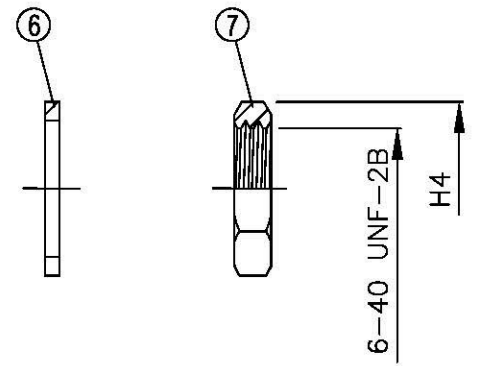
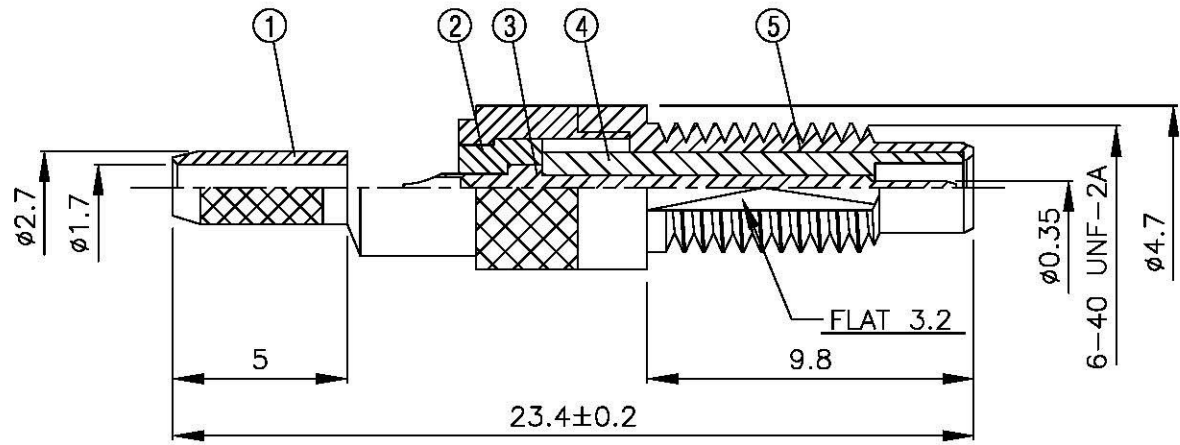
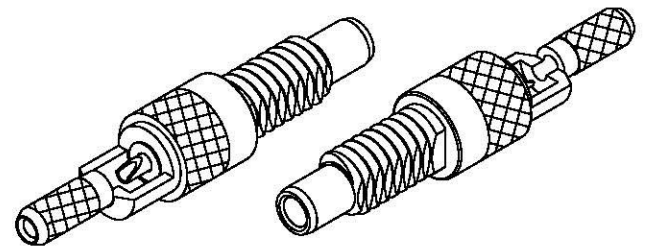

All Connectors
 www.allconnectors.de info@allconnectors.de
 Tel: +49 431 307850 Fax: +49 431 307850
 22794 Hohenstedt, Germany Kettensmiede 25

TITLE SSMC MALE CRIMP FOR RG 316/U

PART NO. SSMC-05LV1-TGG

DRAWING NO. SSMC 05LV1 TGG

DRAWN MARY	DATE 96.07.09
CHECKED 蘇志欣	DATE
Q.A. 蘇姿潔	DATE
APPROVAL 徐燦霖	DATE
REVISION	DATE

DIMENSIONS ARE IN MILLIMETERS			
UNLESS OTHERWISE SPECIFIED TOLERANCE			
0.5-5=±0.2	120-315=±1		
5-30=±0.4	315-1000=±1.6		
30-120±0.6	1000-2000=±2.4		
SCALE 4:1	SIZE A		

REVISION	
DESCRIPTION	ENGINEER