

NO	DESCRIPTION	MATERIAL	Q'TY	FINISH	REMARK
1	PIN	PH.BRONZE	1	GOLD	P-SSMC0307-G
2	INSULATION 1	TEFLON	1	TEFLON	I-0227T
3	BODY 1	BRASS	1	GOLD	B-SSMB0250-G
4	BODY 2	BRASS	1	GOLD	B-SSMC0462-G
5	INSULATION 2	TEFLON	1	TEFLON	I-0113T
6	WASHER	BRASS	1	GOLD	W-0017-G

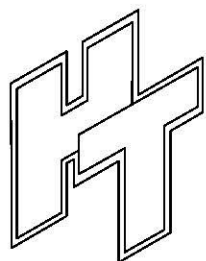
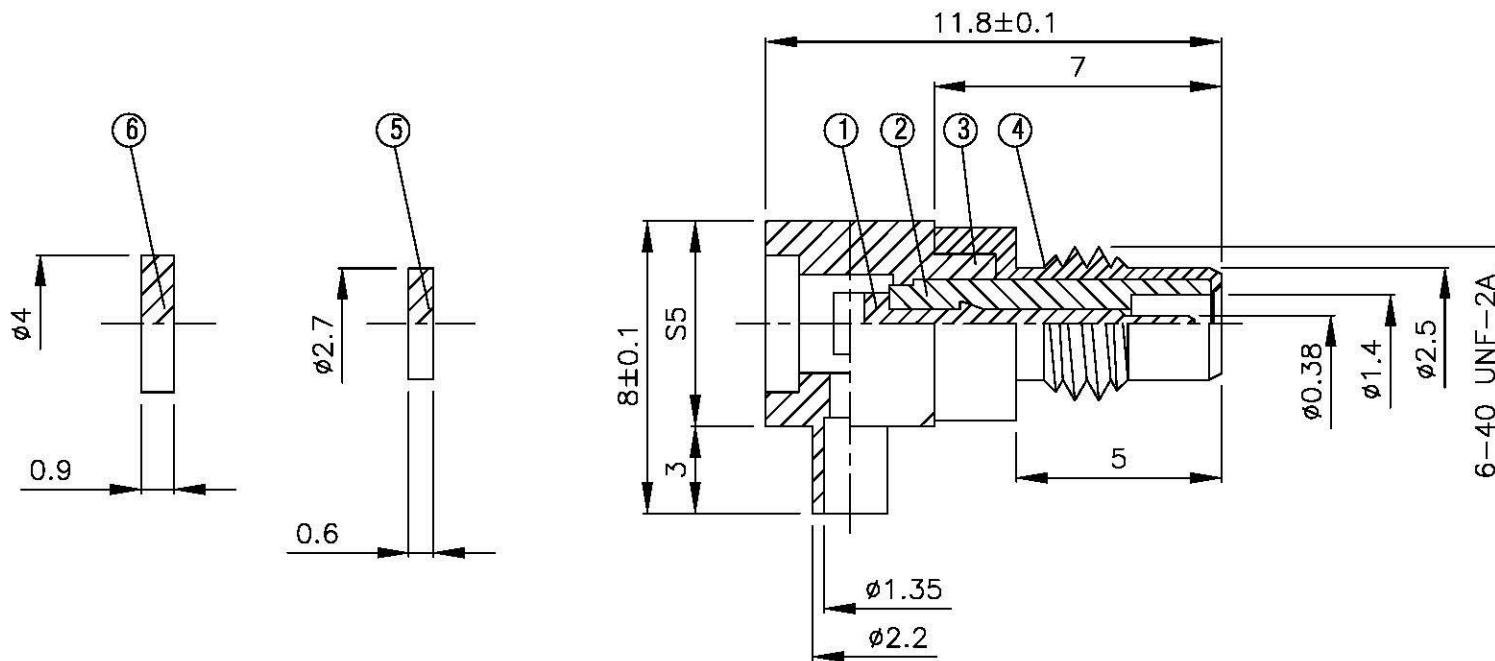
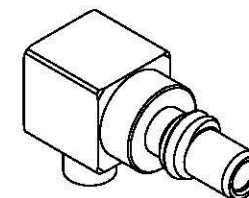

**All Connectors**

www.allconnectors.de  
Tel.: 0049 711 7006503  
20791 Filderbach - Germany

info@allconnectors.de  
Fax: 0049 711 7006504  
certificates: 25

TITLE SSMC MALE ANGLE SOLDER  
FOR M17/151 (.047)

PART NO. SSMC-04V3-TGG

DRAWING NO. SSMC 04V3 TGG

DRAWN MARY DATE 96.07.09

CHECKED 蘇志欣 DATE

Q.A. 蘇姿潔 DATE

APPROVAL 徐燦霖 DATE

REVISION DATE

DIMENSIONS ARE IN MILLIMETERS

UNLESS OTHERWISE SPECIFIED  
TOLERANCE

0.5-5=±0.2 120-315=±1

5-30=±0.4 315-1000=±1.6

30-120±0.6 1000-2000=±2.4

SCALE 4:1 SIZE A

REVISION

DESCRIPTION ENGINEER

D

C

B

A

D

C

B

A

4

3

2

1