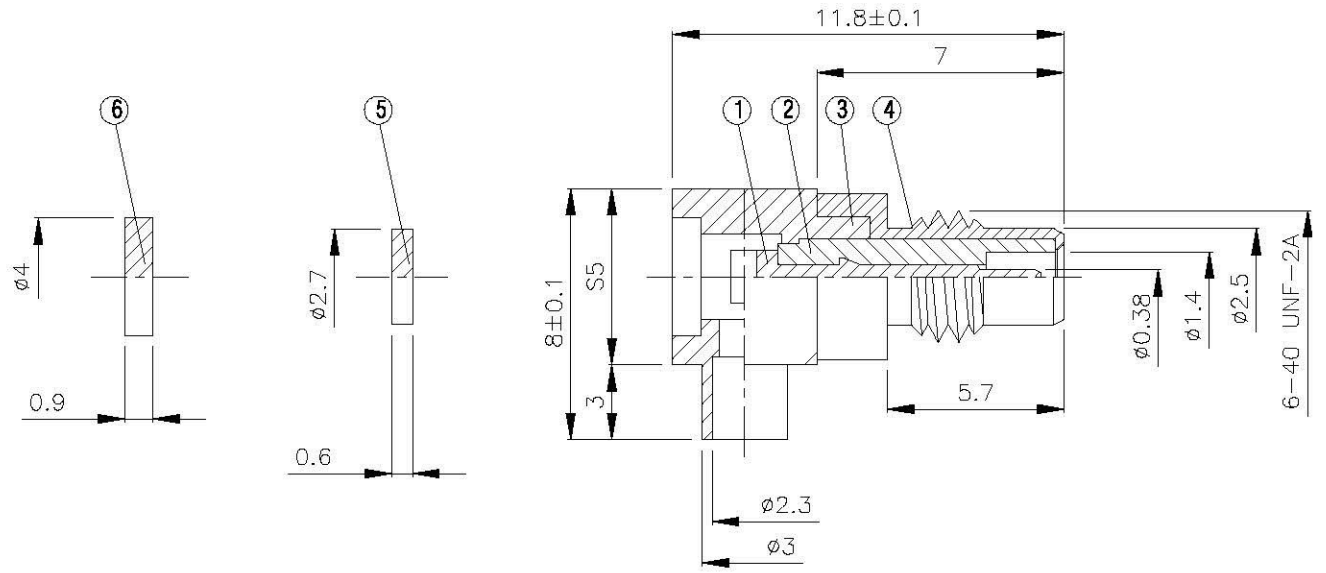
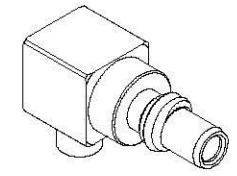
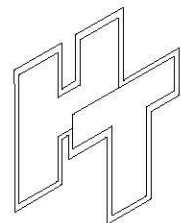

NO	DESCRIPTION	MATERIAL	Q'TY	FINISH	REMARK
1	PIN	PH.BRONZE	1	GOLD	P-SSMC0307-G
2	INSULATION 1	TEFLON	1	TEFLON	I-0227T
3	BODY 1	BRASS	1	GOLD	B-SSMB0249-G
4	BODY 2	BRASS	1	GOLD	B-SSMC0462-G
5	INSULATION 2	TEFLON	1	TEFLON	I-0113T
6	WASHER	BRASS	1	GOLD	W-0017-G

**All Connectors**  
www.allconnectors.de    info@allconnectors.de  
 Tel: +49 4343 9199100    Fax: +49 4343 9199104  
 33093 Allerstadt - Germany    Kettweg 25

**TITLE** SSMC MALE ANGLE SOLDER FOR RG405 (.085)

**PART NO.** SSMC-04V1-TGG

**DRAWING NO.** SSMC 04V1 TGG

<b>DRAWN</b> MARY	<b>DATE</b> 96.07.09
<b>CHECKED</b> 蘇志欣	<b>DATE</b>
<b>Q.A.</b> 蘇姿潔	<b>DATE</b>
<b>APPROVAL</b> 徐燦霖	<b>DATE</b>
<b>REVISION</b>	<b>DATE</b>

<b>DIMENSIONS ARE IN MILLIMETERS</b>			
<b>UNLESS OTHERWISE SPECIFIED TOLERANCE</b>			
0.5-5=±0.2	120-315=±1		
5-30=±0.4	315-1000=±1.6		
30-120±0.6	1000-2000=±2.4		
<b>SCALE</b> 4:1	<b>SIZE</b> A		

<b>REVISION</b>	
DESCRIPTION	ENGINEER