

NO	DESCRIPTION	MATERIAL	Q'TY	FINISH	REMARK
1	PIN	PH.BRONZE	1	GOLD	P-SSMC0307-G
2	INSULATION 1	TEFLON	1	TEFLON	I-0227T
3	BODY 1	BRASS	1	GOLD	B-SSMB0248-G
4	BODY 2	BRASS	1	GOLD	B-SSMC0462-G
5	INSULATION 2	TEFLON	1	TEFLON	I-0113T
6	WASHER	BRASS	1	GOLD	W-0017-G
7	RING	BRASS	1	GOLD	R-0038-G

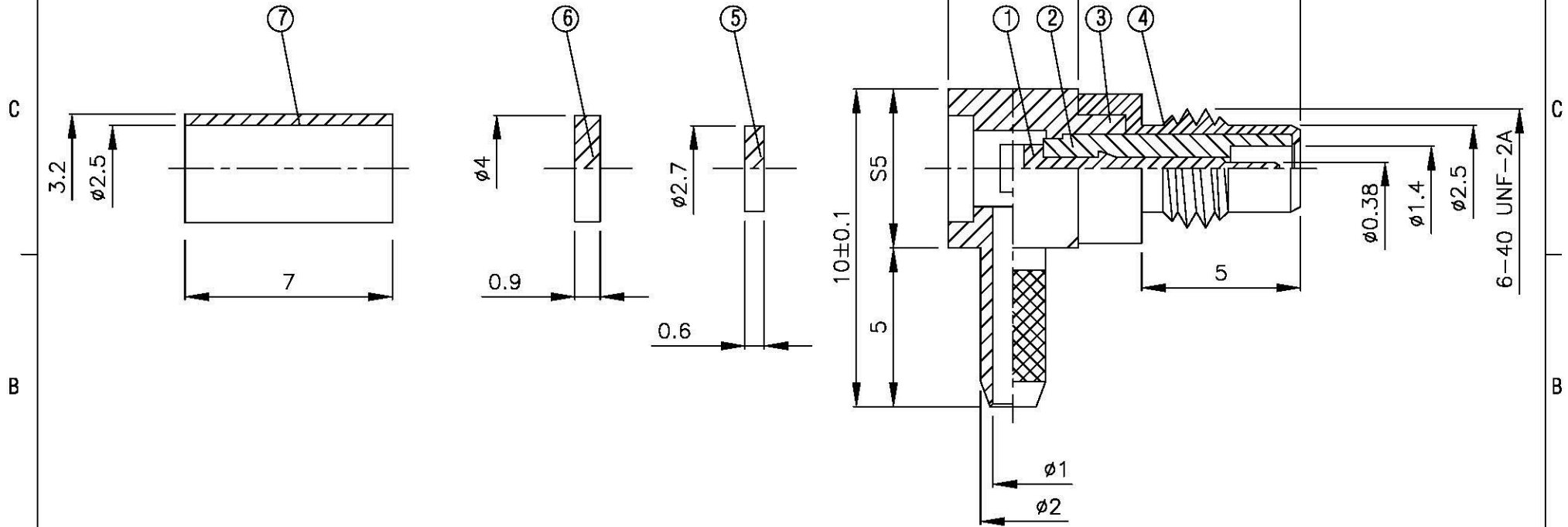
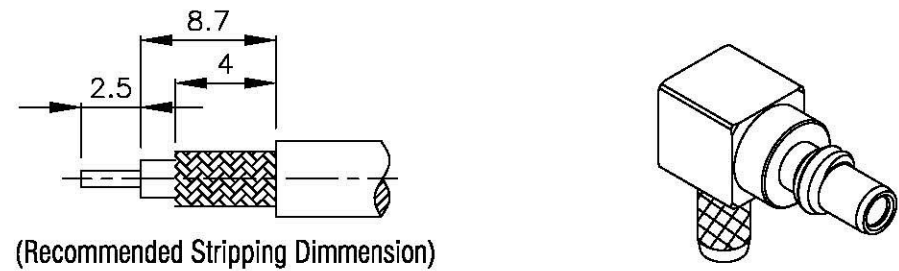

		DRAWN	MARY	DATE	96.07.09	DIMENSIONS ARE IN MILLIMETERS		REVISION	
	<small>www.allconnectors.com</small> <small>TEL: 0086-0514-8811111</small> <small>FAX: 0086-0514-8811111</small>	CHECKED	蘇志欣	DATE		UNLESS OTHERWISE SPECIFIED TOLERANCE		DESCRIPTION	ENGINEER
	TITLE	SSMC MALE ANGLE CRIMP FOR RG 178/U		Q.A.	蘇姿潔	DATE			
	PART NO.	SSMC-04M-TGG		APPROVAL	徐燦霖	DATE		0.5-5=±0.2	120-315=±1
	DRAWING NO.	SSMC 04M TGG		REVISION		DATE		5-30=±0.4	315-1000=±1.6
							30-120±0.6	1000-2000=±2.4	
						SCALE	4:1	SIZE	A