

NO	DESCRIPTION	MATERIAL	Q'TY	FINISH	REMARK
1	BODY 1	BRASS	1	GOLD	B-SSMB0247-G
2	INSULATION 1	TEFLON	1	TEFLON	I-0051T
3	PIN	PH.BRONZE	1	GOLD	P-SSMC0308-G
4	INSULATION 2	TEFLON	1	TEFLON	I-0228T
5	BODY 2	BRASS	1	GOLD	B-SSMC0462-G
6	RING	BRASS	GOLD	R-0033-G	

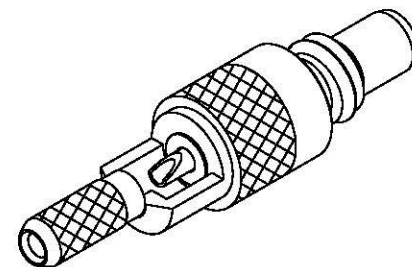

(Recommended Stripping Dimension)

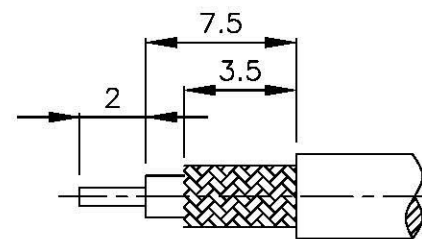
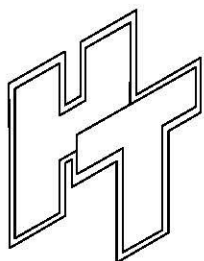
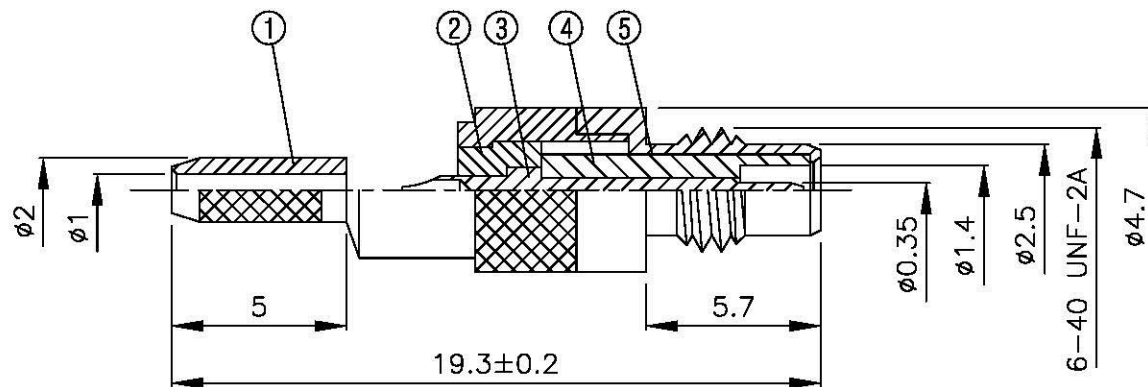
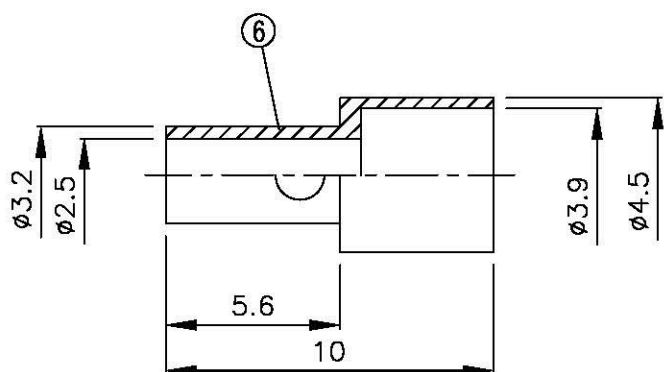

All Connectors

www.allconnectors.de
Tel.: 0049 711 7009503
79724 Floßstadt - Germany

info@allconnectors.de
Tel: 0049 711 7009504
Kettnerstr. 25

TITLE SSMC MALE CRIMP FOR
RG178/U

PART NO. SSMC-03M-TGG

DRAWING NO. SSMC 03M TGG

DRAWN MARY DATE 96.07.09

CHECKED 蘇志欣 DATE

Q.A. 蘇姿潔 DATE

APPROVAL 徐燦霖 DATE

REVISION DATE

DIMENSIONS ARE IN MILLIMETERS

UNLESS OTHERWISE SPECIFIED
TOLERANCE

0.5-5=±0.2 120-315=±1

5-30=±0.4 315-1000=±1.6

30-120±0.6 1000-2000=±2.4

REVISION

DESCRIPTION ENGINEER

SCALE 4:1 SIZE A