

| NO | DESCRIPTION | MATERIAL | Q'TY | FINISH | REMARK |
|----|--------------|-----------|------|----------|--------------|
| 1 | BODY 1 | BRASS | 1 | GOLD | B-SSMB0241-G |
| 2 | INSULATION 1 | TEFLON | 1 | TEFLON | I-0051T |
| 3 | PIN | PH.BRONZE | 1 | GOLD | P-SSMC0308-G |
| 4 | INSULATION 2 | TEFLON | 1 | TEFLON | I-0228T |
| 5 | BODY 2 | BRASS | 1 | GOLD | B-SSMC0462-G |
| 6 | RING | BRASS | GOLD | R-0032-G | |

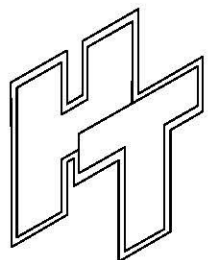
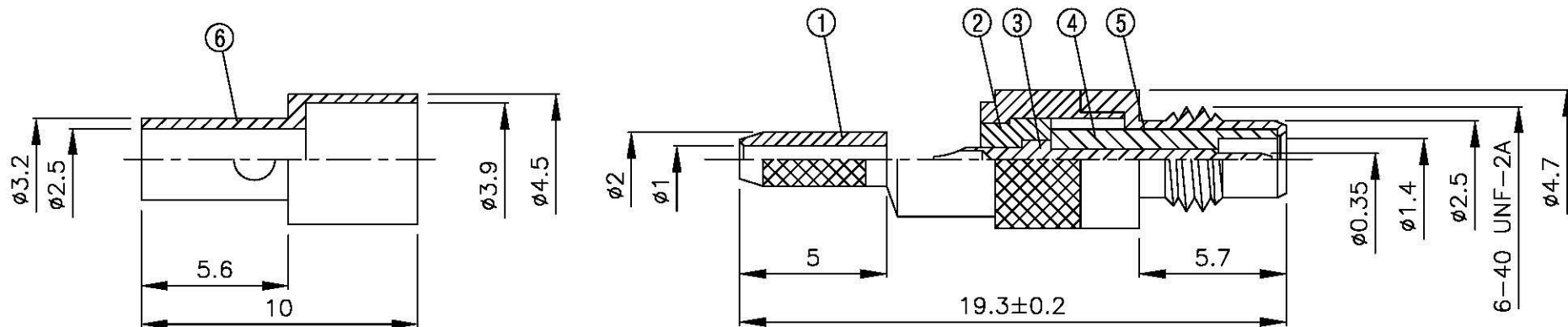
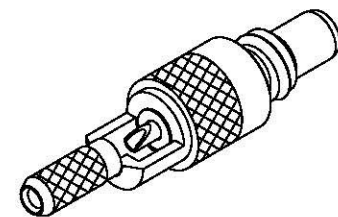

Allconnectors
 www.allconnectors.com info@allconnectors.com
 Tel: +49 429 742 70000 Fax: +49 429 742 70004
 70704 Filzschlitz - Germany Kallmannstr. 23

TITLE SSMC MALE CRIMP FOR
RG 316/U

PART NO. SSMC-03LV1-TGG

DRAWING NO. SSMC 03LV1 TGG

| | | | |
|----------|------|------|----------|
| DRAWN | MARY | DATE | 96.07.09 |
| CHECKED | 蘇志欣 | DATE | |
| Q.A. | 蘇姿潔 | DATE | |
| APPROVAL | 徐燦霖 | DATE | |
| REVISION | | DATE | |

DIMENSIONS ARE IN MILLIMETERS

| UNLESS OTHERWISE SPECIFIED TOLERANCE | |
|--------------------------------------|----------------|
| 0.5-5=±0.2 | 120-315=±1 |
| 5-30=±0.4 | 315-1000=±1.6 |
| 30-120±0.6 | 1000-2000=±2.4 |

SCALE 4:1 SIZE A

| REVISION | |
|-------------|----------|
| DESCRIPTION | ENGINEER |
| | |
| | |
| | |