

NO	DESCRIPTION	MATERIAL	Q'TY	FINISH	REMARK
1	BODY 1	BRASS	1	GOLD	B-SSMB0891-G
2	INSULATION 1	TEFLON	1	TEFLON	I-0431T
3	PIN	BE CU	1	GOLD	P-SSMB0624-G
4	BODY 2	BRASS	1	GOLD	B-SSMC1025-G
5	INSULATION 2	TEFLON	1	TEFLON	I-0113T
6	WASHER	BRASS	1	GOLD	W-0017-G
7	WASHER	BRASS	1	GOLD	W-0060-G
8	NUT	BRASS	1	GOLD	N-0034-G

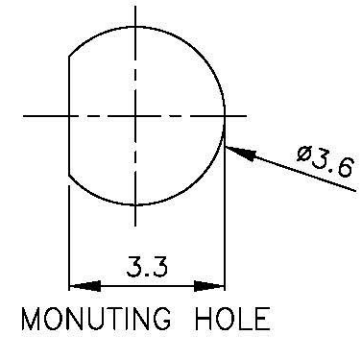
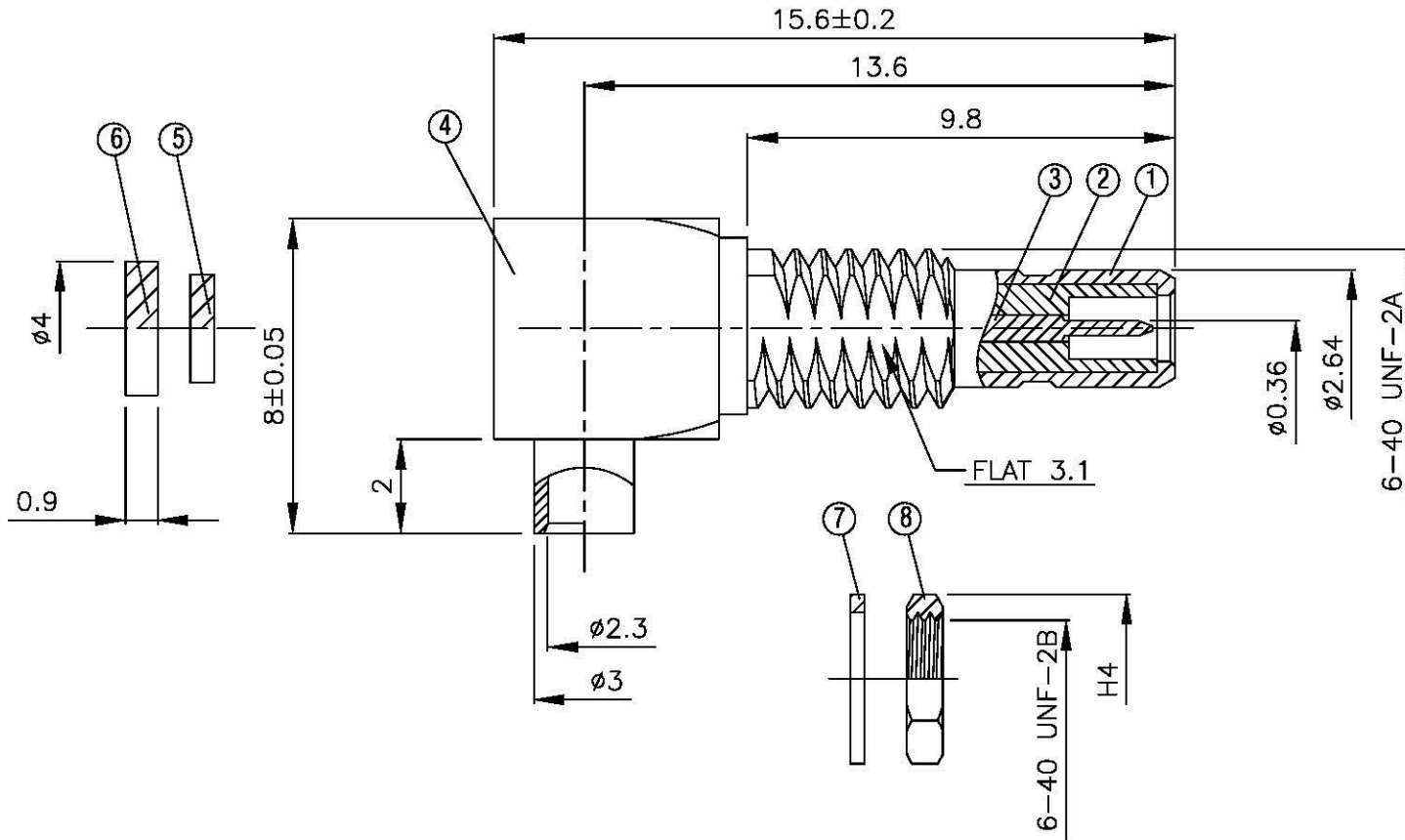
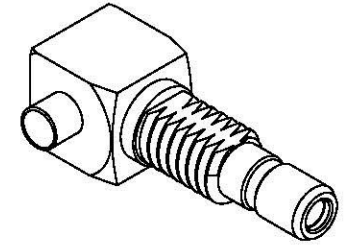
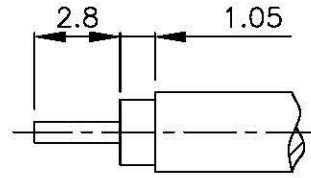
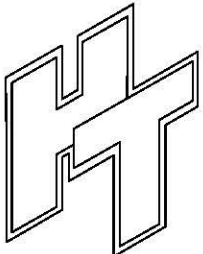

	All Connectors <small>www.allconnectors.de tel. +49 531 7007610 39294 Hainstedt - Germany</small>	DRAWN MARY DATE 94.11.29	DIMENSIONS ARE IN MILLIMETERS		REVISION	
		CHECKED 沈佳德 DATE 94.11.29	UNLESS OTHERWISE SPECIFIED TOLERANCE		DESCRIPTION	ENGINEER
		Q.A. 蘇姿潔 DATE	XX = ± 0.05 X.X = ± 0.1 X = ± 2 ANGLE = $\pm 2^\circ$			
		APPROVAL 徐燦霖 DATE	SCALE 4:1 SIZE A			
		REVISION	DATE			
TITLE SSMC MALE ANGLE SOLDER FOR RG 405(.085)	PART NO. SSMB-14V1-TGG					
DRAWING NO. SSMB-14V1-TGG						