

NO	DESCRIPTION	MATERIAL	Q'TY	FINISH	REMARK
1	BODY 1	BRASS	1	GOLD	B-SSMB0891-G
2	INSULATION 1	TEFLON	1	TEFLON	I-0430T
3	PIN	BRASS	1	GOLD	P-SSMB0625-G
4	BODY 2	BRASS	1	GOLD	B-SSMB0899-G
5	INSULATION 2	TEFLON	1	TEFLON	I-0434T
6	WASHER	BRASS	1	GOLD	W-0060-G
7	NUT	BRASS	1	GOLD	N-0034-G

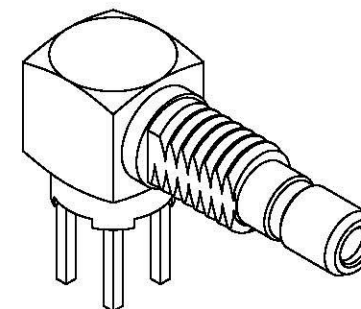

D

D

C

C

B

B

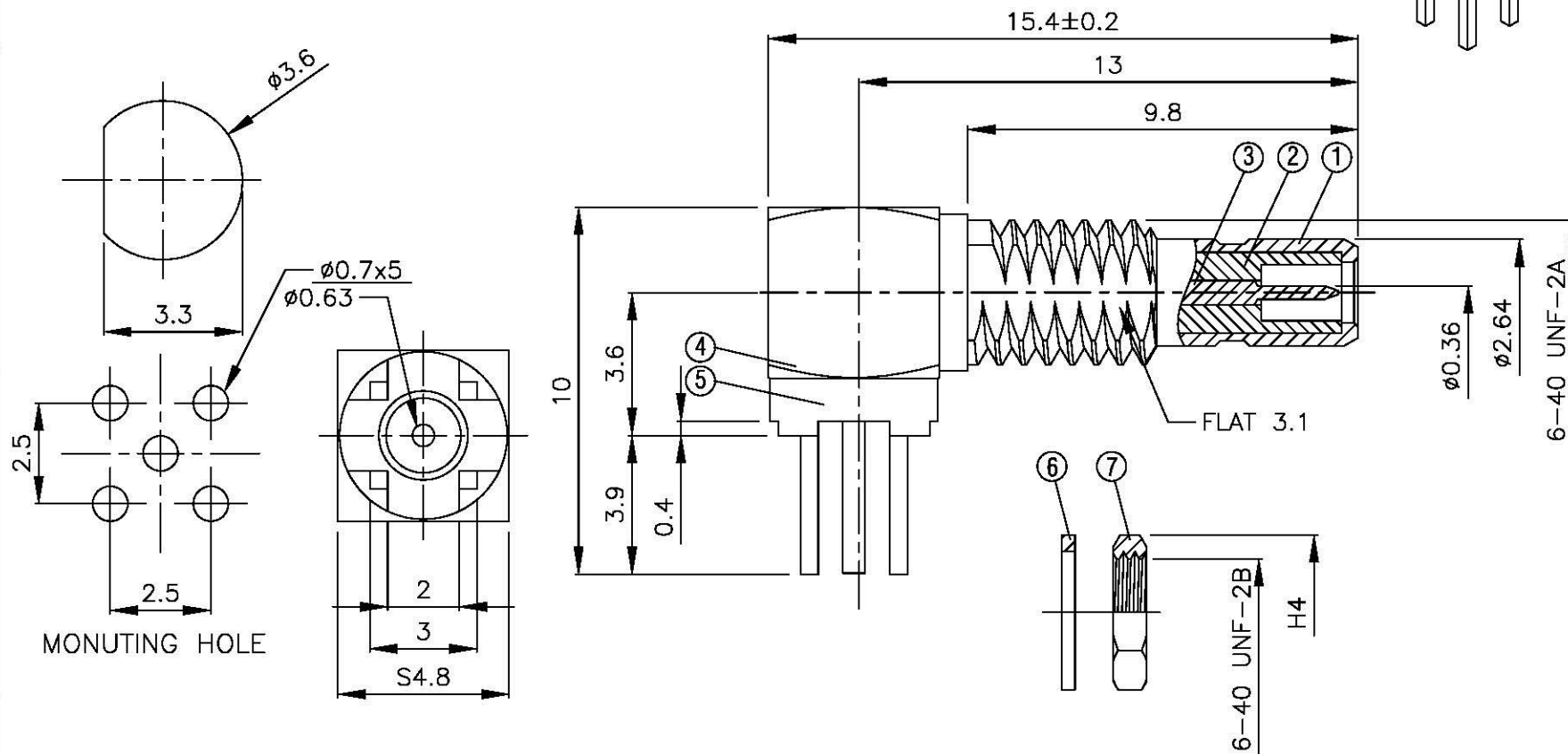

A

A

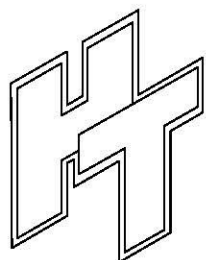

All Connectors

www.allconnectors.de
Tel: +0049 711 7009503
www.allconnectors.com

Info@allconnectors.de
Fax: +0049 711 7009504
Kontakt@allconnectors.de

TITLE **SSMB MALE RIGHT ANGLE RECEPTACLES**

PART NO. **SSMB-05V4-TGG**

DRAWING NO. **SSMB 05V4 TGG**

DRAWN **MARY** DATE **94.03.10**

CHECKED **蘇姿潔** DATE

Q.A. **馮健華** DATE

APPROVA **徐燦霖** DATE

REVISION DATE

DIMENSIONS ARE IN MILLIMETERS

UNLESS OTHERWISE SPECIFIED TOLERANCE

XX = ± 0.05

XX = ± 0.1

X = ± 2

ANGLE = $\pm 2^\circ$

SCALE **4:1** SIZE **A**

REVISION

DESCRIPTION ENGINEER

4

3

2

1