

NO	DESCRIPTION	MATERIAL	Q'TY	FINISH	REMARK
1	PIN	BRASS	1	GOLD	P-SSMB0177-G
2	INSULATION 1	TEFLON	1	TEFLON	I-0083T
3	BODY 1	BRASS	1	GOLD	B-SSMB0249-G
4	BODY 2	BRASS	1	GOLD	B-SSMB0296-G
5	INSULATION 2	TEFLON	1	TEFLON	I-0113T
6	WASHER	BRASS	1	GOLD	W-0017-G

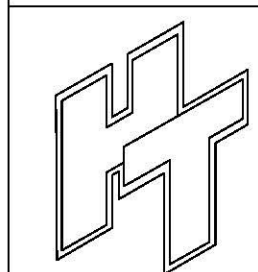
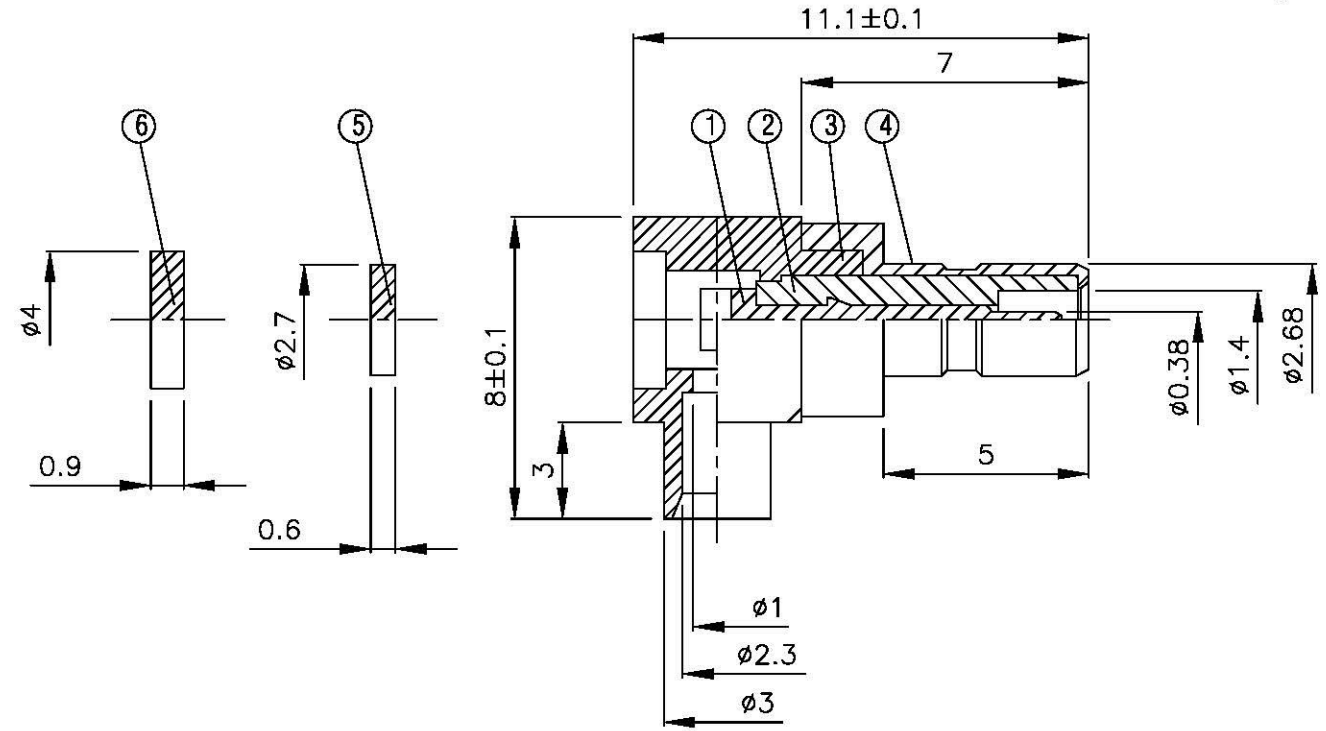
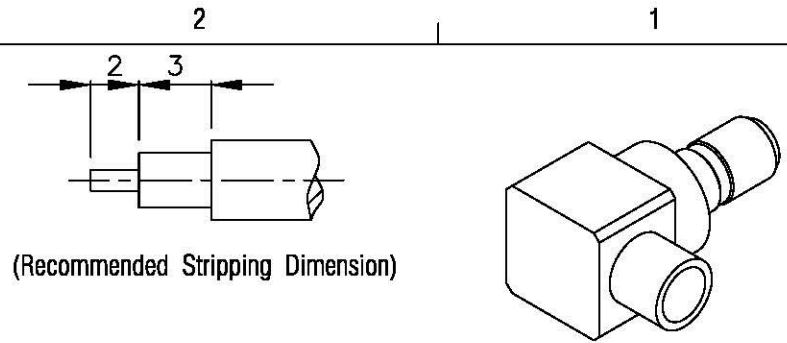

All Connectors
 www.allconnectors.de info@allconnectors.de
 Tel: 0049 714 706504 Fax: 0049 714 706505
 70794 Ellersdorf - Germany Kellernstr. 25

TITLE SSMB MALE ANGLE SOLDER FOR RG405(.085)

PART NO. SSMB-04V1-TGG

DRAWING NO. SSMB 04V1 TGG

DRAWN MARY **DATE** 96.07.05

CHECKED 蘇志欣 **DATE**

Q.A. 蘇姿潔 **DATE**

APPROVAL 徐燦霖 **DATE**

REVISION **DATE**

DIMENSIONS ARE IN MILLIMETERS

UNLESS OTHERWISE SPECIFIED TOLERANCE

0.5-5=±0.2	120-315=±1
5-30=±0.4	315-1000=±1.6
30-120±0.6	1000-2000=±2.4

SCALE 4:1 **SIZE** A

REVISION	
DESCRIPTION	ENGINEER