

NO	DESCRIPTION	MATERIAL	Q'TY	FINISH	REMARK
1	BODY 1	BRASS	1	GOLD	B-SSMB0247-G
2	INSULATION 1	TEFLON	1	TEFLON	I-0051T
3	PIN	BE CU	1	GOLD	P-SSMB0143-G
4	INSULATION 2	TEFLON	1	TEFLON	I-0050T
5	BODY 2	BE CU	1	GOLD	B-SSMB0240-G
6	BODY 3	BRASS	1	GOLD	B-SSMB0242-G
7	RING	BRASS	1	GOLD	R-0033-G

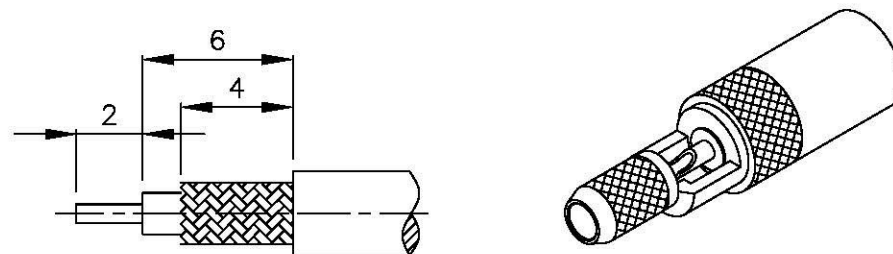

(Recommended Stripping Dimension)

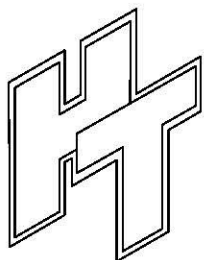
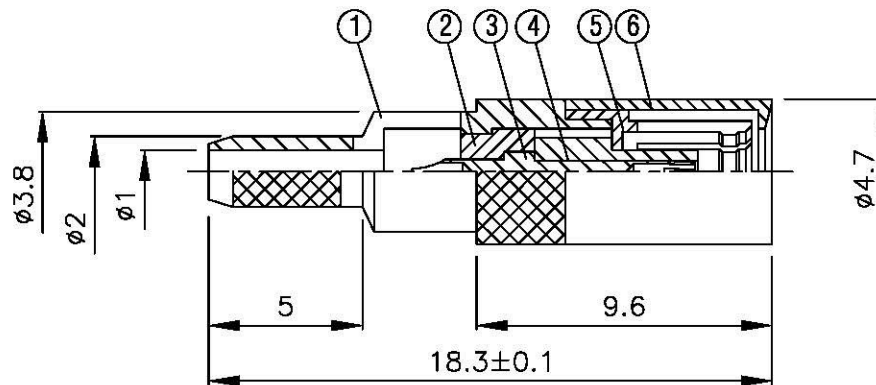
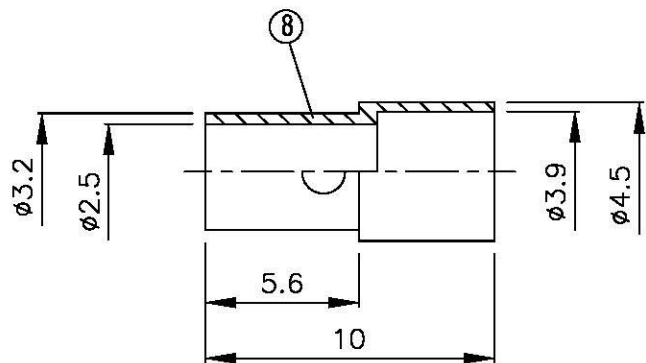

Allconnectors

www.allconnectors.de
tel: +49 44 40 17 10 00 0
50754 Ffilsdorf, Germany

info@allconnectors.de
fax: +49 44 40 17 10 00 4
Köln, Germany, 50754

TITLE
SSMB MALE CRIMP FOR RG 178/U

PART NO.
SSMB-01M-TGG

DRAWING NO.
SSMB 01M TGG

DRAWN MARY DATE 96.07.05

CHECKED 蘇志欣 DATE

Q.A. 蘇姿潔 DATE

APPROVAL 徐燦霖 DATE

REVISION DATE

DIMENSIONS ARE IN MILLIMETERS

UNLESS OTHERWISE SPECIFIED TOLERANCE

0.5-5=±0.2 120-315=±1

5-30=±0.4 315-1000=±1.6

30-120±0.6 1000-2000=±2.4

SCALE 4:1 SIZE A

REVISION

DESCRIPTION ENGINEER

D

C

B

A

D

C

B

A