

NO	DESCRIPTION	MATERIAL	Q'TY	FINISH	REMARK
1	BODY 1	BRASS	1	NICKEL	B-SMZ0604-G
2	INSULATION	TEFLON	1	TEFLON	I-0459T
3	BODY 2	BRASS	1	GOLD	B-SMZ0754-G
4	WASHER	BRASS	1	NICKEL	W-0065-N
5	BODY 3	BRASS	1	NICKEL	B-SMZ0755-G
6	PIN	BE CU	1	GOLD	P-SMZ0442-G
7	RING	BRASS	1	NICKEL	R-0002-G
8	WASHER	BRASS	1	NICKEL	W-0023-G
9	INSULATION	TEFLON	1	TEFLON	I-0136T

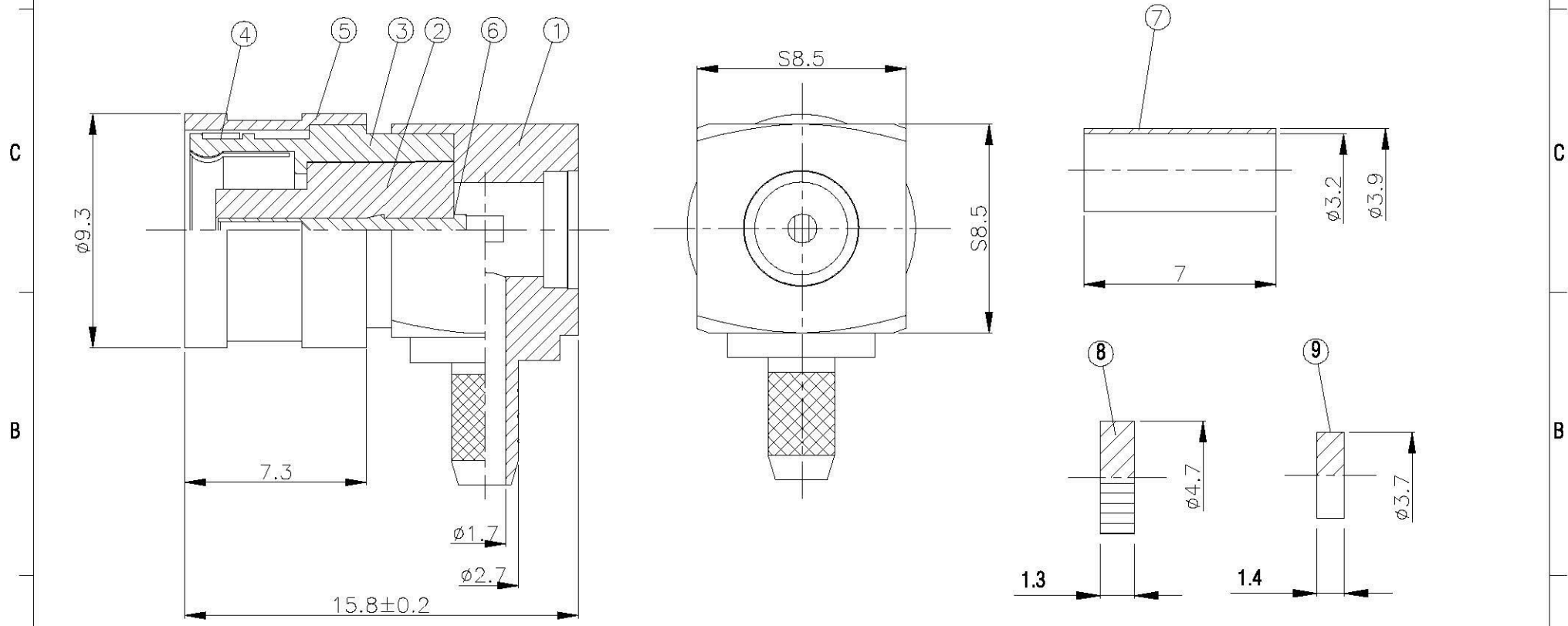
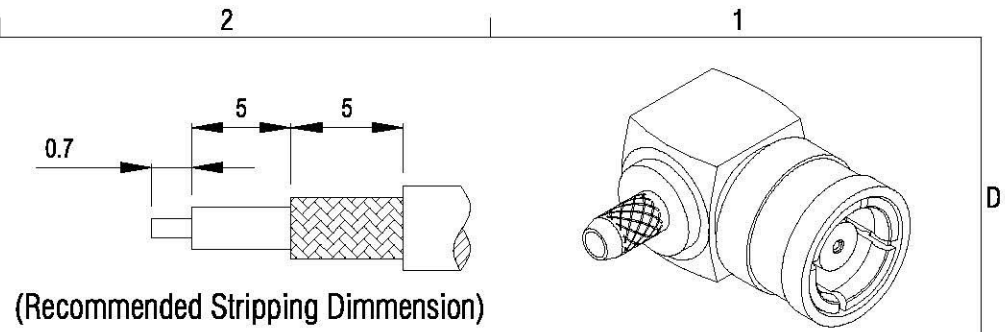

	 <small>www.allconnectors.de Tel.: 0049 231 4016100 70794 Flörsbachtal, Germany</small>	DRAWN 蘇姿潔 CHECKED 蘇志欣 Q.A. 林妙樺 APPROVAL 徐燦霖 REVISION	DATE 97.01.05 DATE DATE DATE DATE	DIMENSIONS ARE IN MILLIMETERS UNLESS OTHERWISE SPECIFIED TOLERANCES 0.5-5 = ± 0.2 120-315 = ± 1 5-30 = ± 0.4 315-1000 = ± 1.6 30-120 = ± 0.6 1000-2000 = ± 2.4	REVISION DESCRIPTION ENGINEER
	TITLE SMZ JACK CRIMP FOR RG-179/U	APPROVAL 徐燦霖	SCALE 4:1 SIZE A		
	PART NO. SMZ-07N-TGG				
	DRAWING NO. SMZ 07N TGG				