

NO	DESCRIPTION	MATERIAL	Q'TY	FINISH
1	BODY 1	BRASS	1	GOLD
2	INSULATION 1	TEFLON	1	TEFLON
3	INSULATION 2	TEFLON	1	TEFLON
4	PIN	BE CU	1	GOLD
5	BODY 2	BRASS	1	GOLD
6	BODY 3	BRASS	1	GOLD
7	WASHER	PH.BRONZE	1	GOLD

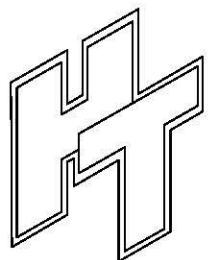
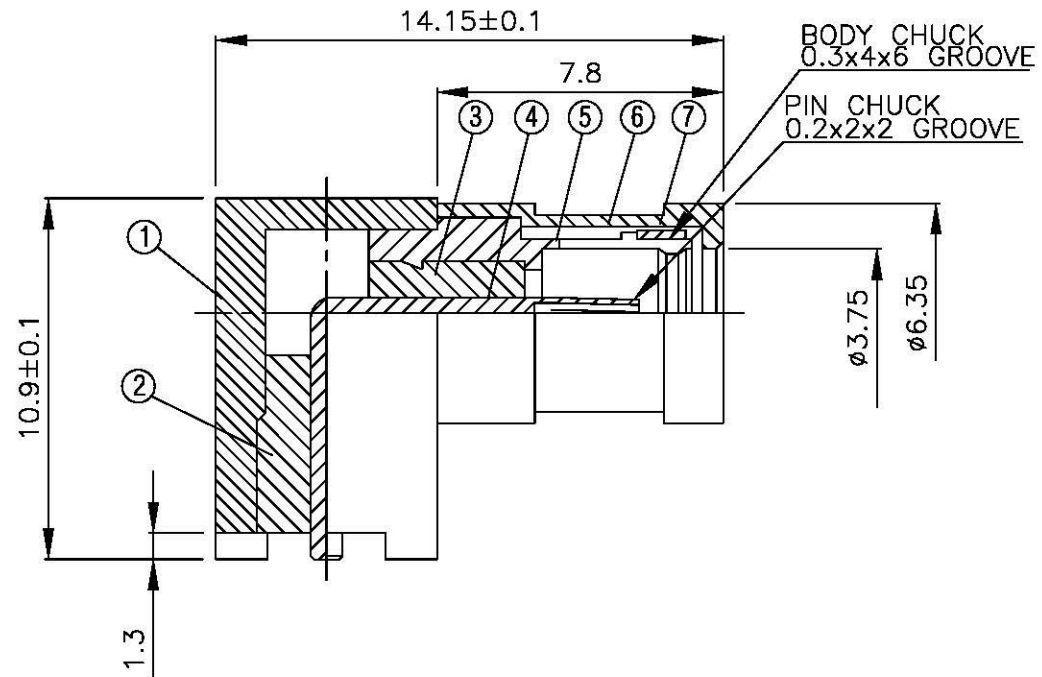
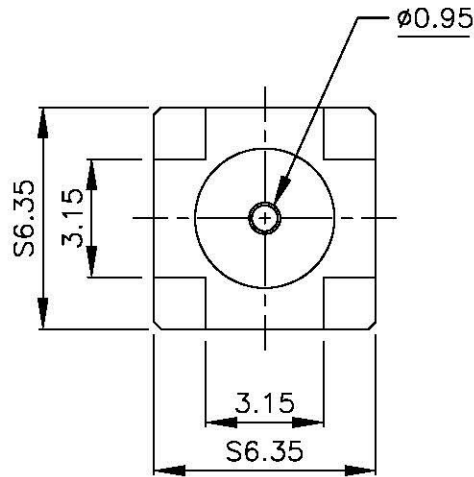
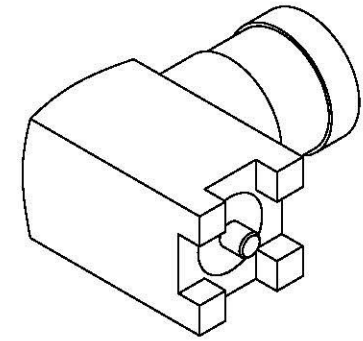
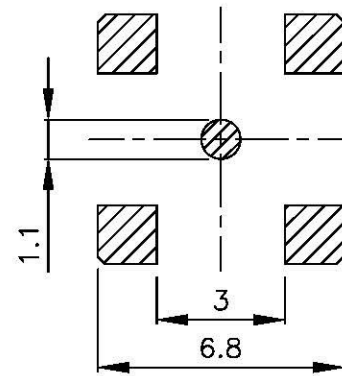

**All Connectors**

www.allconnectors.se  
TEL: 0800 211 0000  
Korsnäs Hållarskåp - Teamwork

info@allconnectors.se  
Fax: 0844 711 200004  
Korsnäs Hållarskåp

TITLE  
SMB FEMALE ANGLE SURFACE MOUNT

PART NO. SMB-06V4-TGG-75

DRAWING NO. SMB 06V4 TGG 75

DRAWN MARY DATE 96.09.04

CHECKED 黃巧君

Q.A. 蘇姿潔

APPROVED 徐燦霖

REVISION DATE

DIMENSIONS ARE IN MILLIMETERS

UNLESS OTHERWISE SPECIFIED  
TOLERANCE

0.5-5=±0.2 120-315=±1

5-30=±0.4 315-1000=±1.6

30-120±0.6 1000-2000=±2.4

SCALE 4:1 SIZE A

REVISION

DESCRIPTION ENGINEER