

NO	DESCRIPTION	MATERIAL	Q'TY	FINISH	REMARK
1	BODY 1	BRASS	1	GOLD	B-SMB0256-G
2	BODY 2	BRASS	1	GOLD	B-SMB0263-G
3	INSULATION 1	TEFLON	1	TEFLON	I-0054T
4	BODY 3	BRASS	1	GOLD	B-SMB0245-G
5	PIN	BE CU	1	GOLD	P-SMB0146-G
6	WASHER	BE CU	1	GOLD	W-0035

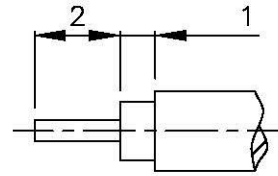

(Recommended Stripping Dimension)

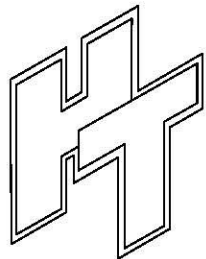
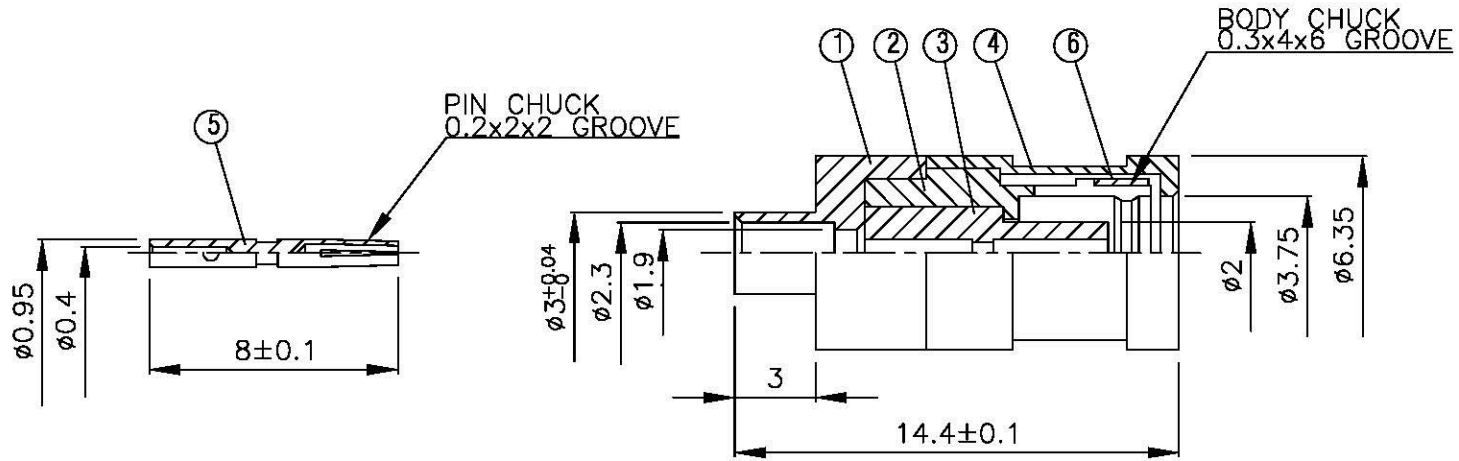
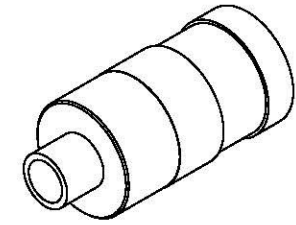

Allconnectors

www.allconnectors.com
 Tel: 0049 711 2009503
 76204 Hilderstadt - Germany

Info@allconnectors.com
 Fax: 0049 711 2009504
 Kettnerstr. 25

DRAWN	MARY	DATE	96.03.13
CHECKED	黄巧君	DATE	
Q.A.	蘇姿潔	DATE	
APPROVAL	徐燦霖	DATE	
REVISION		DATE	

TITLE SMB FEMALE SOLDER FOR RG405 (.085)

PART NO. SMB-02V1-TGG

DRAWING NO. SMB 02V1 TGG

DIMENSIONS ARE IN MILLIMETERS

UNLESS OTHERWISE SPECIFIED TOLERANCE

0.5-5=±0.2	120-315=±1
5-30=±0.4	315-1000=±1.6
30-120±0.6	1000-2000=±2.4

SCALE 4:1 SIZE A

REVISION

DESCRIPTION	ENGINEER