

NO	DESCRIPTION	MATERIAL	Q'TY	FINISH	REMARK
1	BODY 1	BRASS	1	GOLD	B-SMB0490-G
2	BODY 2	BRASS	1	GOLD	B-SMB0479-G
3	INSULATION 1	TEFLON	1	TEFLON	I-0242T
4	BODY 3	BRASS	1	GOLD	B-SMB0245-G
5	PIN	BE CU	1	GOLD	P-SMB0332-G
6	WASHER	BRESS	1	GOLD	W-0035-G
7	RING	BRASS	1	GOLD	R-0007-G

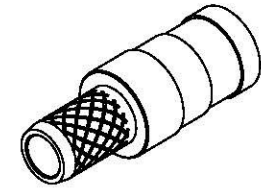

(Recommended Stripping Dimension)

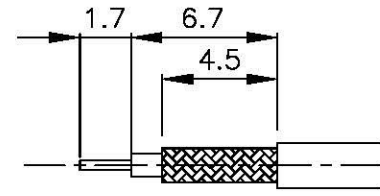
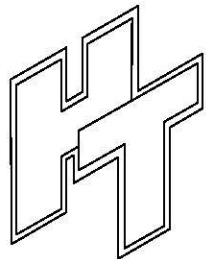
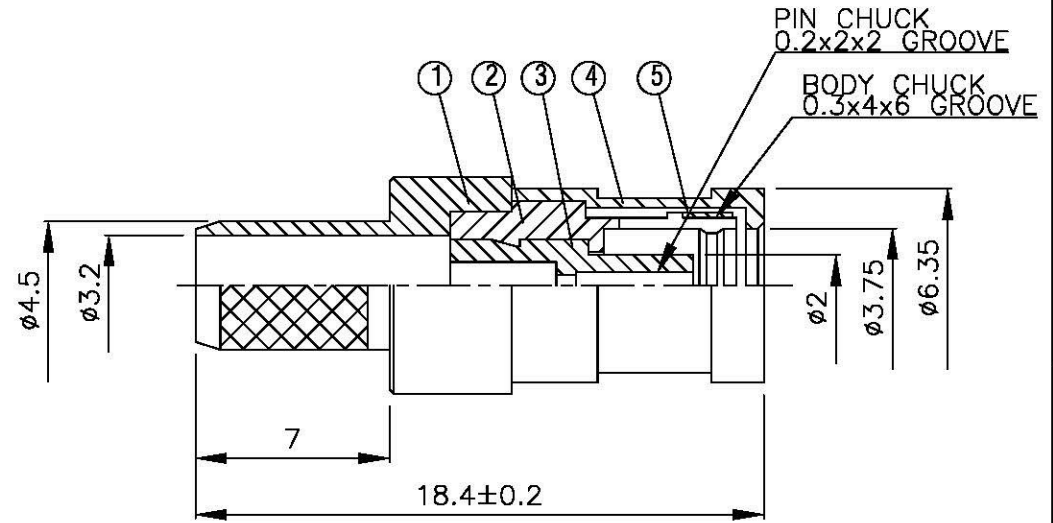
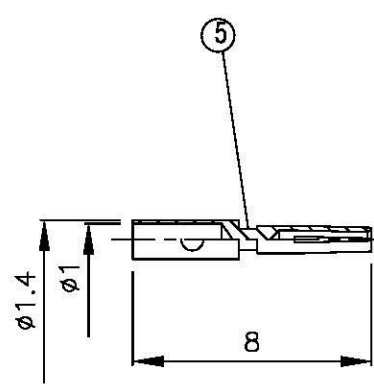
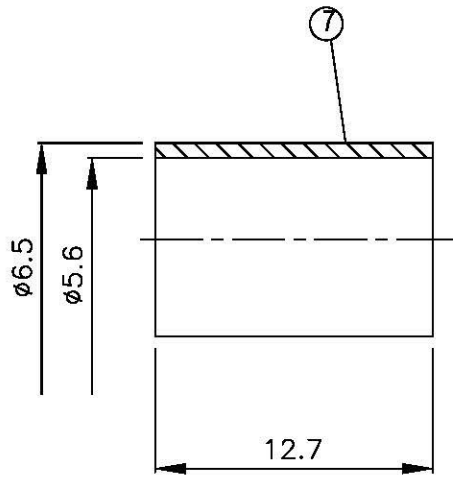

**All Connectors**

Wuxue 4, Haimen City, Jiangsu  
 Tel: 8681 321 9509500  
 207911 Tielandstr. - Germany

TITLE **SMB FEMALE CRIMP FOR RG 58/U**

PART NO. **SMB-02F-TGG**

DRAWING NO. **SMB 02F-TGG**

DRAWN	MARY	DATE	92.04.17
CHECKED	黃巧君	DATE	92.04.17
Q.A.	蘇姿潔	DATE	
APPROVAL	徐燦霖	DATE	
REVISION		DATE	

DIMENSIONS ARE IN MILLIMETERS

UNLESS OTHERWISE SPECIFIED TOLERANCE

0.5-5=±0.2	120-315=±1
5-30=±0.4	315-1000=±1.6
30-120±0.6	1000-2000=±2.4

SCALE 4:1 SIZE A

REVISION

DESCRIPTION	ENGINEER