

NO	DESCRIPTION	MATERIAL	Q'TY	FINISH	REMARK
1	BODY 1	BRASS	1	GOLD	B-SMB0167-G
2	INSULATION	TEFLON	1	TEFLON	I-0023T
3	BODY 2	BRASS	1	GOLD	B-SMB0175-G
4	PIN	BRASS	1	GOLD	P-SMB0116-G

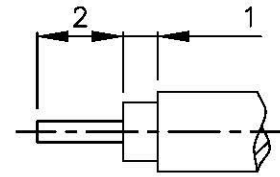

(Recommended Stripping Dimension)

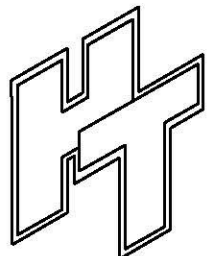
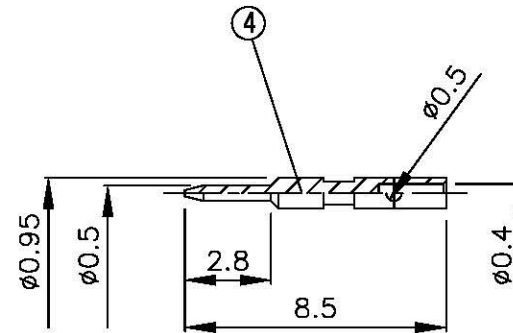
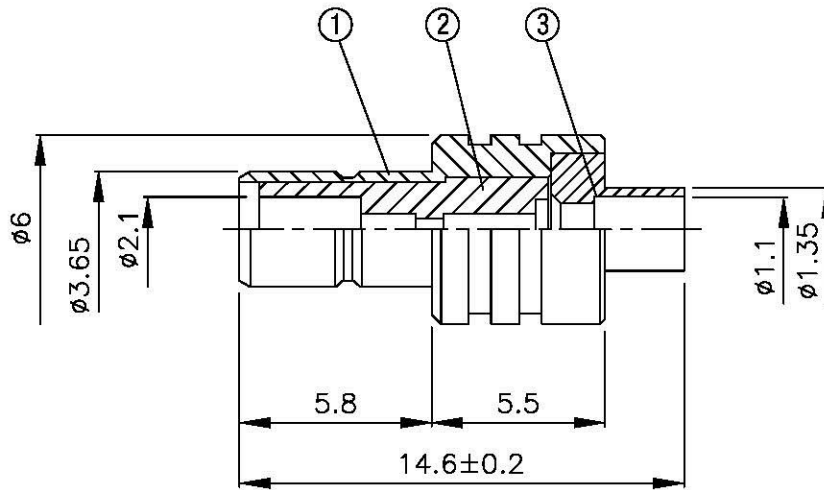
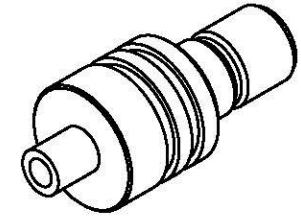

All Connectors

www.allconnectors.com
Tel: 0049 714 7068206
00755 815618371 (Germany)

TITLE **SMB MALE SOLDER FOR (.047)**

PART NO. **SMB-01V3-TGG**

DRAWING NO. **SMB 01V3 TGG**

DRAWN **MARY** DATE **96.03.14**

CHECKED **蘇姿潔** DATE

Q.A. **張育誌** DATE

APPROVAL **馮健華** DATE

REVISION DATE

DIMENSIONS ARE IN MILLMETERS

UNLESS OTHERWISE SPECIFIED TOLERANCE
 0.5-5=±0.2 120-315=±1
 5-30= ±0.4 315-1000=±1.6
 30-120±0.6 1000-2000=±2.4

SCALE **4:1** SIZE **A**

REVISION

DESCRIPTION	ENGINEER

4

3

2

1