

NO	DESCRIPTION	MATERIAL	Q'TY	FINISH	REMARK
1	BODY	BRASS	1	NICKEL	B-SMA0155-N
2	BODY	BRASS	1	NICKEL	B-SMA0145-N
3	INSULATION	TEFLON	1	TEFLON	I-0198T
4	PIN	BE CU	1	GOLD	P-SMA0818-G
5	RING	BRASS	1	NICKEL	R-0002-N
6	NUT	BRASS	2	GOLD	N-0006-N
7	WASHER	BRASS	2	GOLD	W-0016-N
8	WASHER	BRASS	1	GOLD	W-0023-N
9	INSULATION	TEFLON	1	TEFLON	I-0136T

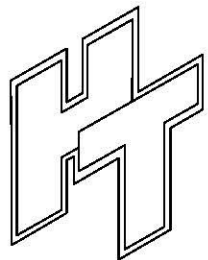
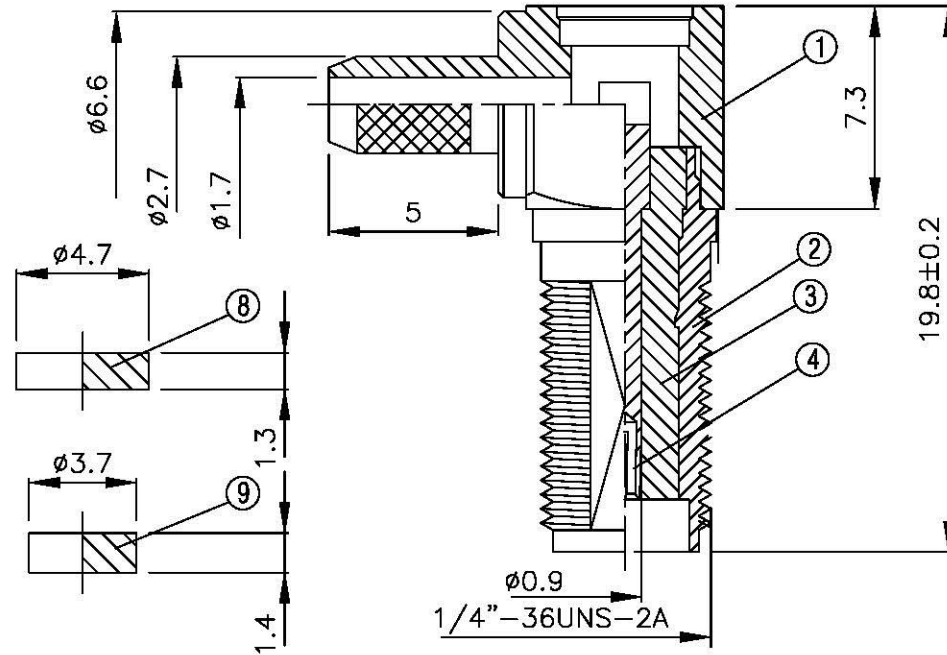
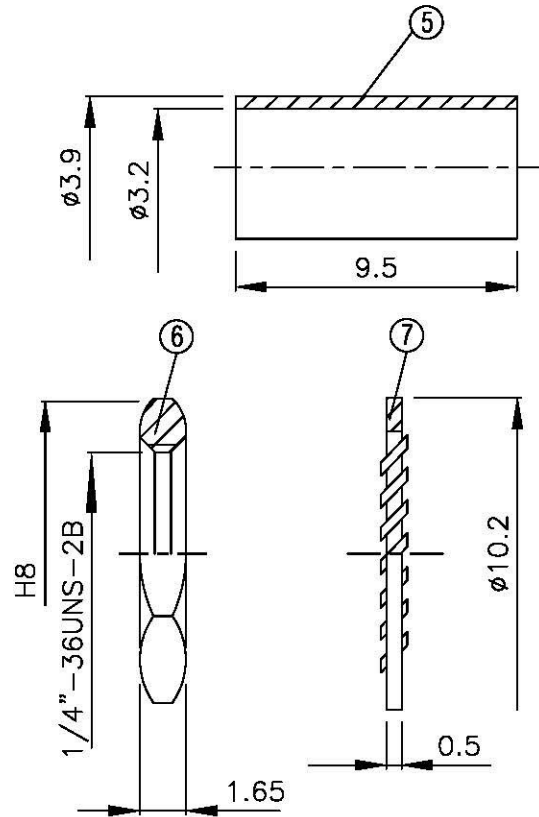
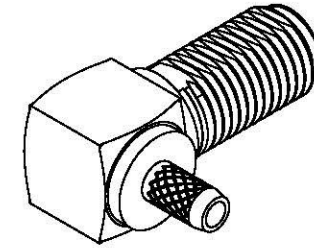
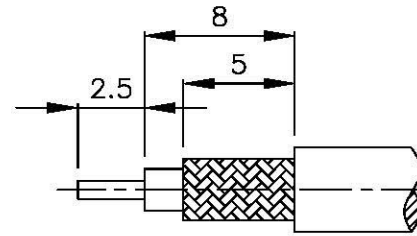

All Connectors

www.allconnectors.de
Tel.: 0049 711 7005503
70754 Norderstact - Germany

info@allconnectors.de
Fax: 0049 711 7005504
Kettnerstr. 25

TITLE SMA FEMALE CRIMP
FOR RG 174U

PART NO. SMA-93LV1-TGN

DRAWING NO. SMA 93LV1 TGN

DRAWN MARY DATE 96.02.12

CHECKED 黄巧君 DATE

Q.A. 蘇姿潔 DATE

APPROVAL 徐燦霖 DATE

REVISION DATE

DIMENSIONS ARE IN MILLIMETERS

UNLESS OTHERWISE SPECIFIED
TOLERANCE

0.5-5=±0.2 120-315=±1

5-30=±0.4 315-1000=±1.6

30-120±0.6 1000-2000=±2.4

REVISION

DESCRIPTION ENGINEER

SCALE 4:1 SIZE A