

NO	DESCRIPTION	MATERIAL	Q'TY	FINISH	REMARK
1	NUT	BRASS	1	NICKEL	N-0006
2	WASHER	BRASS	1	NICKEL	W-0016
3	GASKET	SI RUBBER	1	RUBBER	RU-0014
4	INSULATION	TEFLON	1	TEFLON	I-0524T
5	BODY	BRASS	1	NICKEL	B-SMA1204-N
6	PIN	BE CU	1	GOLD	P-SMA0864-G
7	RING	BRASS	1	NICKEL	R-0007-N

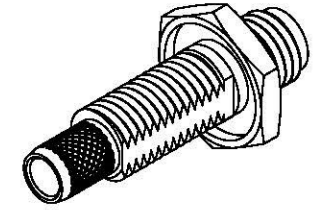

(Recommended Stripping Dimension)

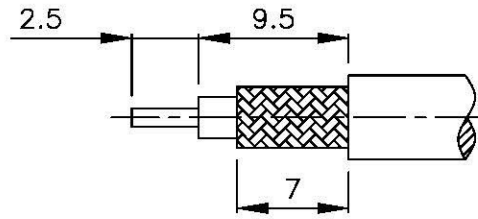
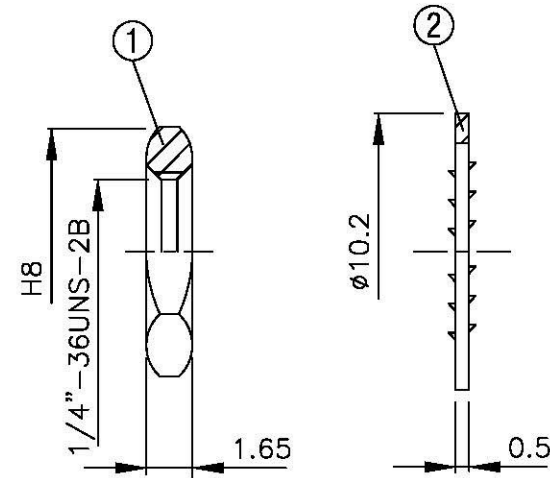
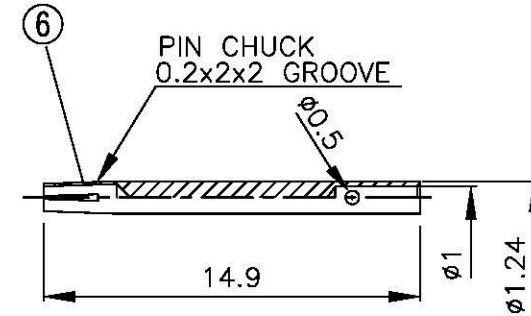
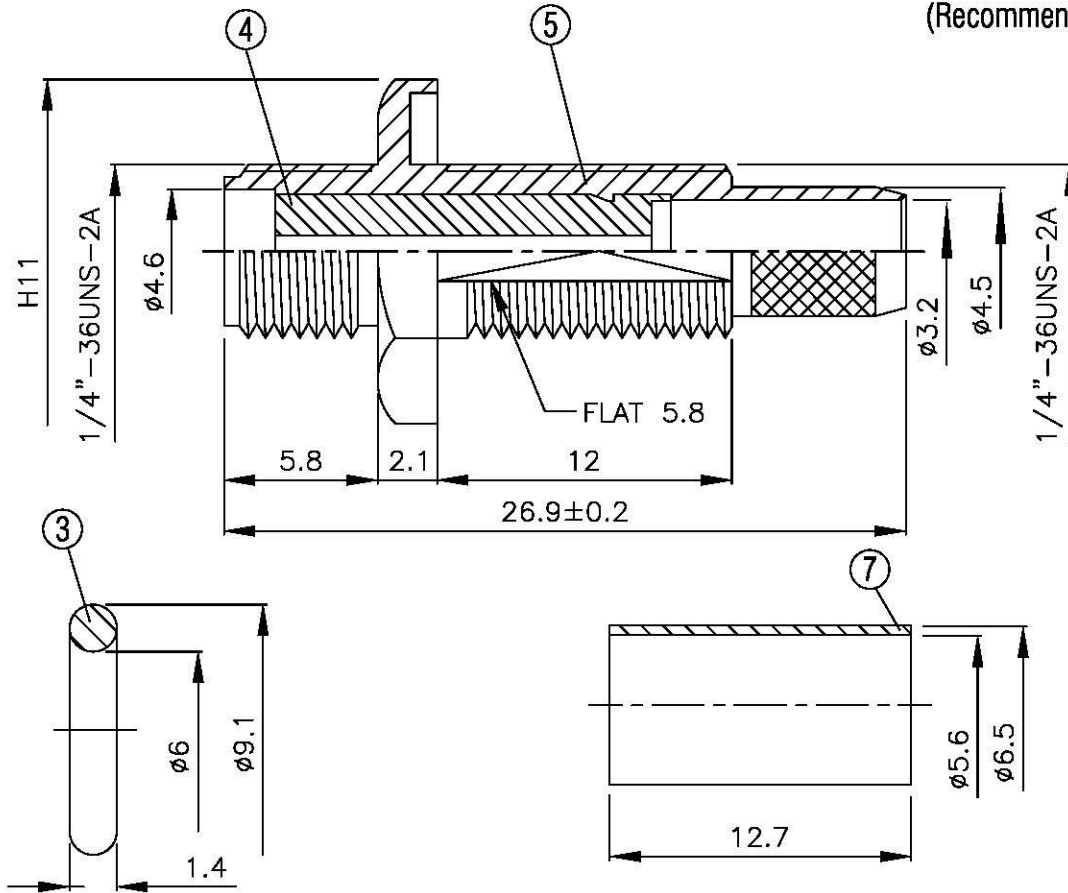

	All Connectors <small>www.allconnectors.de info@allconnectors.de tel: 0049 711 700500 fax: 0049 711 700504 26754 Billdrup Germany Germany</small>	DRAWN MARY DATE 96.08.10	DIMENSIONS ARE IN MILLIMETERS		REVISION	
	TITLE SMA FEMALE CRIMP FOR RG-58/U	CHECKED 蘇姿潔 DATE	UNLESS OTHERWISE SPECIFIED TOLERANCE		DESCRIPTION	ENGINEER
	PART NO. SMA-91F-TGN	Q.A. 馮健華 DATE	0.5-5=±0.2	120-315=±1		
	DRAWING NO. SMA 91F TGN	APPROVAL 徐燦霖 DATE	5-30=±0.4	315-1000=±1.6		
		REVISION DATE	30-120±0.6	1000-2000=±2.4		
		SCALE 4:1	SIZE A			