

NO	DESCRIPTION	MATERIAL	Q'TY	FINISH	REMARK
1	BODY 1	BRASS	1	GOLD	B-SMA0632-G
2	INSULATION 1	TEFLON	1	TEFLON	I-0286T
3	PIN	BE CU	1	GOLD	P-SMB0420-G
4	INSULATION 2	TEFLON	1	TEFLON	I-0053T
5	BODY 2	BRASS	1	GOLD	B-SMC0261-G
6	BODY 3	BRASS	1	GOLD	B-SMC0262-G

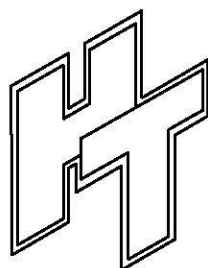
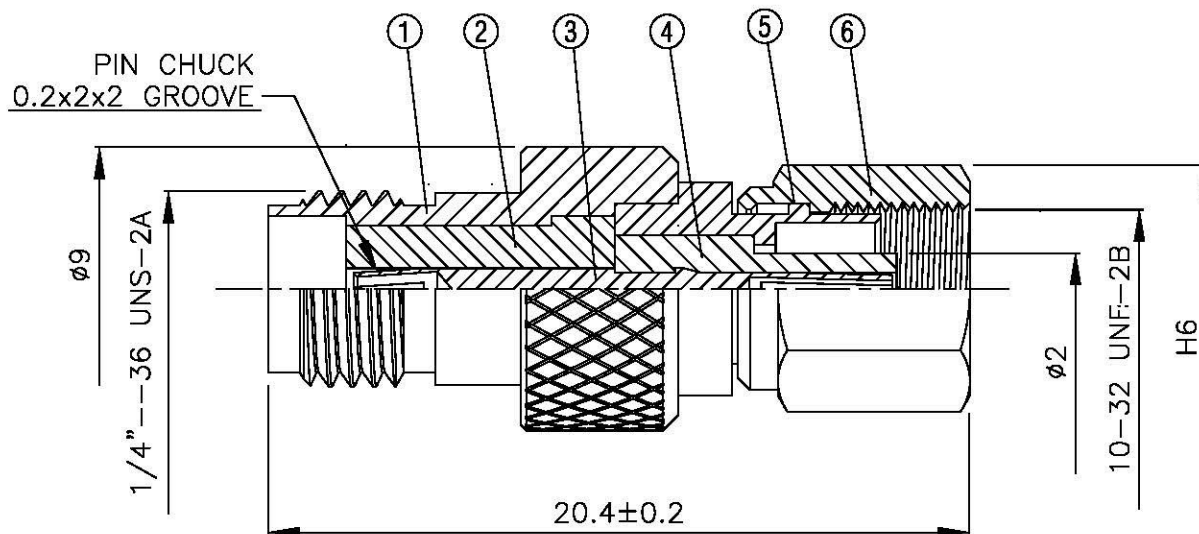
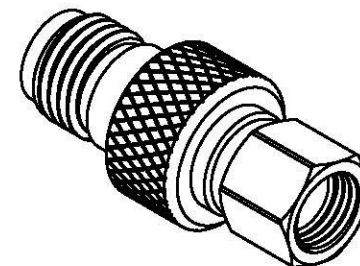

All Connectors
 www.allconnectors.de info@allconnectors.de
 Tel: 0049 731 905042 Fax: 0049 731 905044
 33748 Hildesheim - Germany Kettelerstr. 25

TITLE SMA FEMALE - SMC FEMALE ADAPTOR

PART NO. SMA-74-TGG

DRAWING NO. SMA 74 TGG

DRAWN MARY DATE 96.03.29

CHECKED 黄巧君 DATE

Q.A. 蘇姿潔 DATE

APPROVAL 徐燦霖 DATE

REVISION DATE

DIMENSIONS ARE IN MILLIMETERS

UNLESS OTHERWISE SPECIFIED TOLERANCE

0.5-5=±0.2	120-315=±1
5-30=±0.4	315-1000=±1.6
30-120±0.6	1000-2000=±2.4

SCALE 4:1 SIZE A

REVISION

DESCRIPTION	ENGINEER