

NO	DESCRIPTION	MATERIAL	Q'TY	FINISH	REMARK
1	BODY 1	BRASS	1	GOLD	B-SMA0043-G
2	GASKET	SI RUBBER	1	RUBBER	RU-0008
3	WASHER	PH.BRONZE	1	GOLD	W-0012
4	BODY 2	BRASS	1	GOLD	B-SMA0614-G
5	INSULATION 1	TEFLON	1	TEFLON	I-0286T
6	PIN	BE CU	1	GOLD	P-SMB0417-G
7	INSULATION 2	TEFLON	1	TEFLON	I-0053T
8	BODY 3	BRASS	1	GOLD	B-SMB0263-G
9	BODY 4	BRASS	1	GOLD	B-SMB0245-G
10	WASHER	PH.BRONZE	1	GOLD	W-0035-G

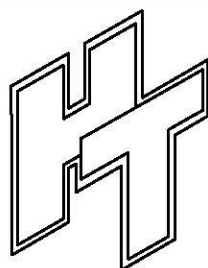
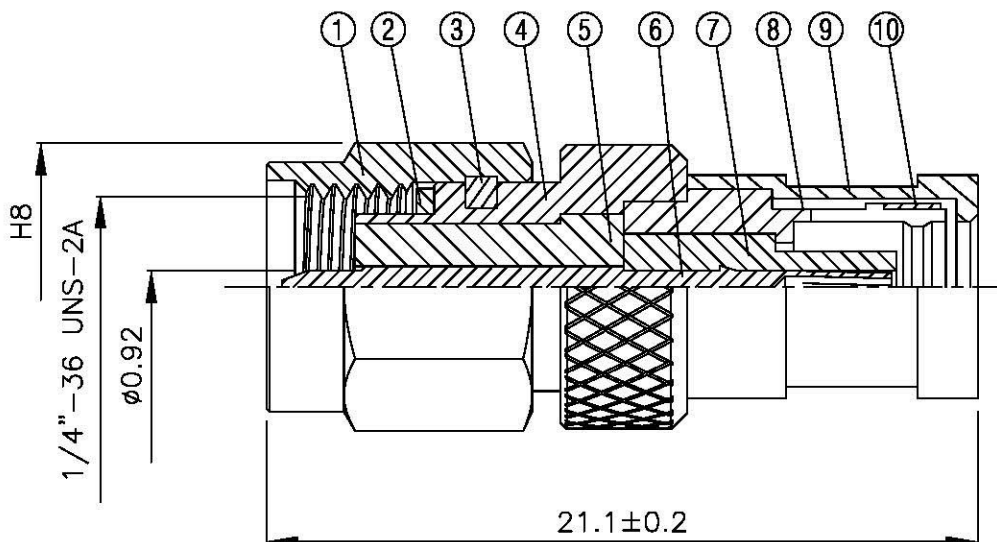
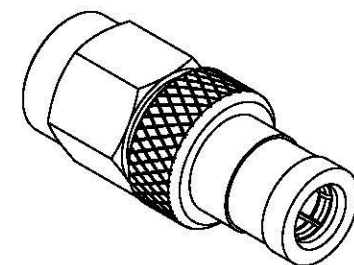

All Connectors
 www.allconnectors.de
 Tel.: 0049 711 7068508
 70794 Ellersstadt - Germany

en@allconnectors.de
 Fax: 0049 711 7068504
 Kettelerstr. 20

TITLE SMA MALE - SMB FEMALE ADAPTOR

PART NO. SMA-69-TGG

DRAWING NO. SMA 69 TGG

DRAWN	MARY	DATE	96.03.29
CHECKED	黄巧君	DATE	
Q.A.	蘇姿潔	DATE	
APPROVAL	徐燦霖	DATE	
REVISION		DATE	

DIMENSIONS ARE IN MILLIMETERS			
UNLESS OTHERWISE SPECIFIED TOLERANCE			
0.5-5=±0.2	120-315=±1		
5-30=±0.4	315-1000=±1.6		
30-120±0.6	1000-2000=±2.4		
SCALE	4:1	SIZE	A

REVISION	
DESCRIPTION	ENGINEER