

NO	DESCRIPTION	MATERIAL	Q'TY	FINISH	REMARK
1	NUT	BRASS	1	GOLD	N-0006
2	WASHER	BRASS	1	GOLD	W-0016
3	INSULATION	TEFLON	1	TEFLON	I-0131T
4	BODY	BRASS	1	GOLD	B-SMA0509-G
5	PIN	BE CU	1	GOLD	P-SMA0064-G

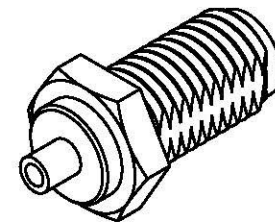

(Recommended Stripping Dimension)

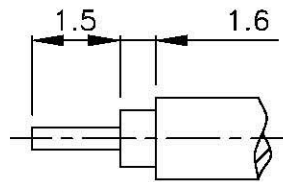
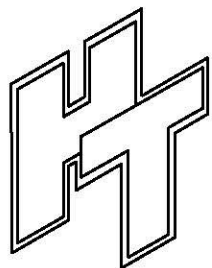
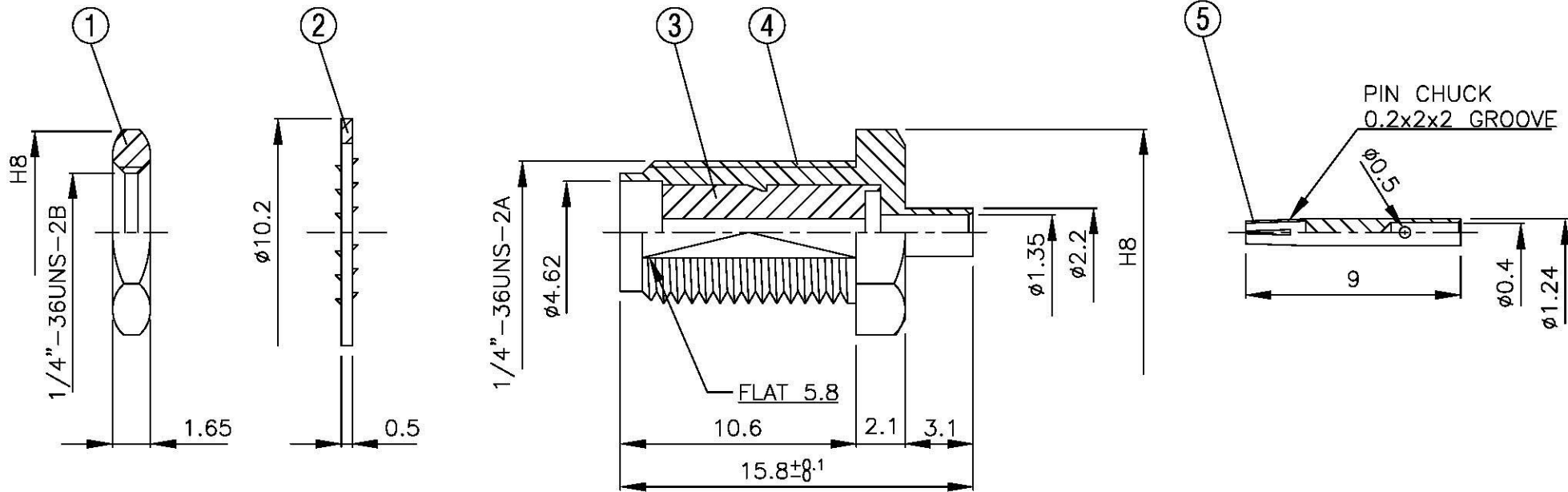

All Connectors

www.allconnectors.de
 info@allconnectors.de
 70794 Filsdorferstr. 25
 70794 Filsdorferstr. 25

TITLE SMA FEMALE SOLDER FOR M17/151 (.047)

PART NO. SMA-56V3-TGG

DRAWING NO. SMA 56V3 TGG

DRAWN MARY DATE 96.03.28

CHECKED 黄巧君 DATE

Q.A. 蘇姿潔 DATE

APPROVAL 徐燦霖 DATE

REVISION DATE

DIMENSIONS ARE IN MILLIMETERS

UNLESS OTHERWISE SPECIFIED TOLERANCE

0.5-5=±0.2	120-315=±1
5-30=±0.4	315-1000=±1.6
30-120±0.6	1000-2000=±2.4

SCALE 4:1 SIZE A

REVISION

DESCRIPTION	ENGINEER