

NO	DESCRIPTION	MATERIAL	Q'TY	FINISH	REMARK
1	NUT	BRASS	1	GOLD	N-0006
2	WASHER	BRASS	1	GOLD	W-0016
3	INSULATION	TEFLON	1	TEFLON	I-0131T
4	BODY	BRASS	1	GOLD	B-SMA0508-G
5	PIN	BE CU	1	GOLD	P-SMA0057-G

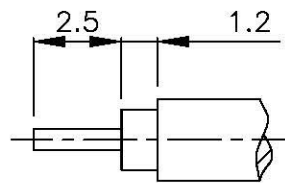

(Recommended Stripping Dimension)

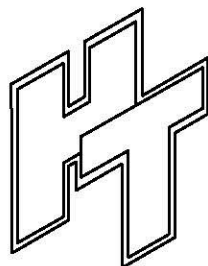
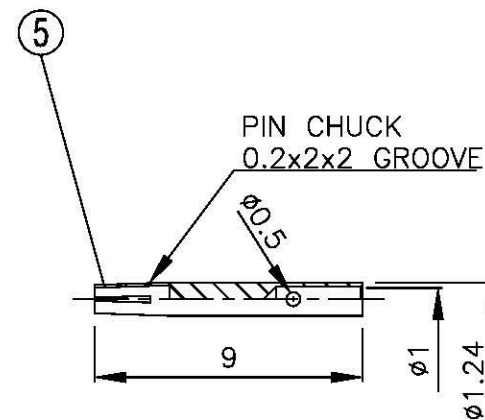
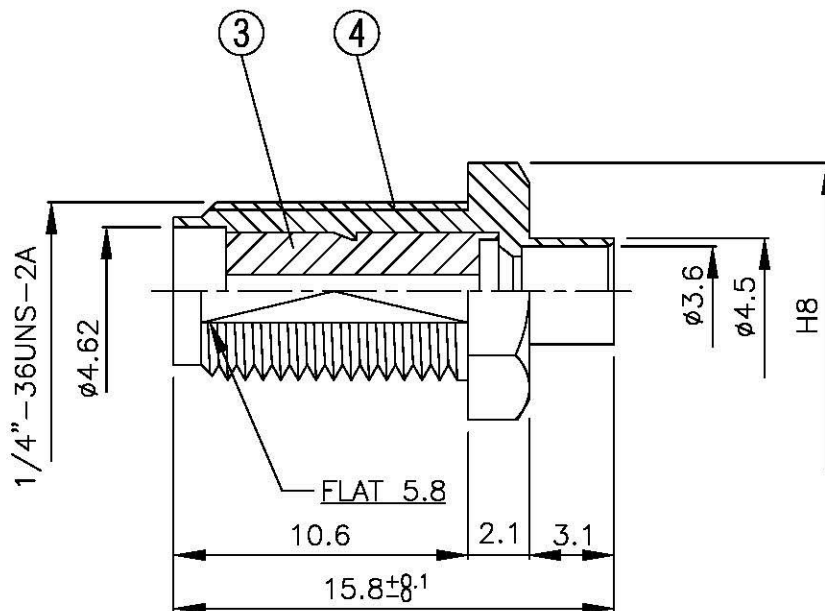
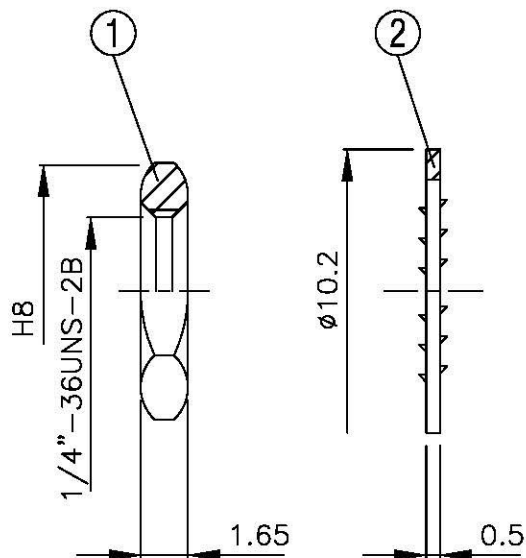
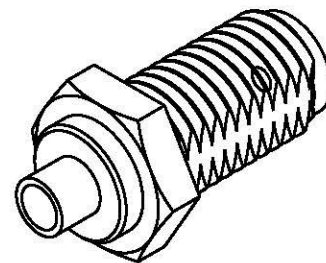

All Connectors
 www.allconnectors.de
 info@allconnectors.de
 Tel.: 0049 / 41 7005941
 Fax: 0049 / 41 7005941
 20794 Füllbrook - Germany
 Web: www.acd.de

TITLE SMA FEMALE SOLDER
 FOR RG 402U(.141)

PART NO. SMA-56V2-TGG

DRAWING NO. SMA 56V2 TGG

DRAWN	MARY	DATE	96.03.28
CHECKED	黄巧君	DATE	
Q.A.	蘇姿潔	DATE	
APPROVAL	徐燦霖	DATE	
REVISION		DATE	

DIMENSIONS ARE IN MILLIMETERS			
UNLESS OTHERWISE SPECIFIED TOLERANCE			
0.5-5=±0.2	120-315=±1		
5-30=±0.4	315-1000=±1.6		
30-120±0.6	1000-2000=±2.4		

SCALE 4:1 SIZE A

REVISION

DESCRIPTION	ENGINEER