

NO	DESCRIPTION	MATERIAL	Q'TY	FINISH	REMARK
1	NUT	BRASS	1	GOLD	N-0006
2	WASHER	BRASS	1	GOLD	W-0016
3	INSULATION	TEFLON	1	TEFLON	I-0131T
4	BODY	BRASS	1	GOLD	B-SMA0507-G
5	PIN	BE CU	1	GOLD	P-SMA0056-G

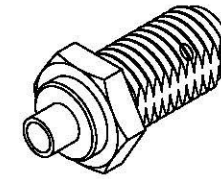

(Recommended Stripping Dimension)

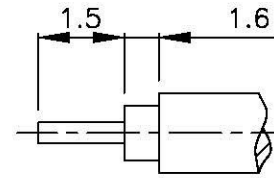
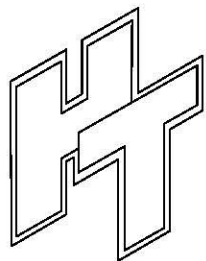
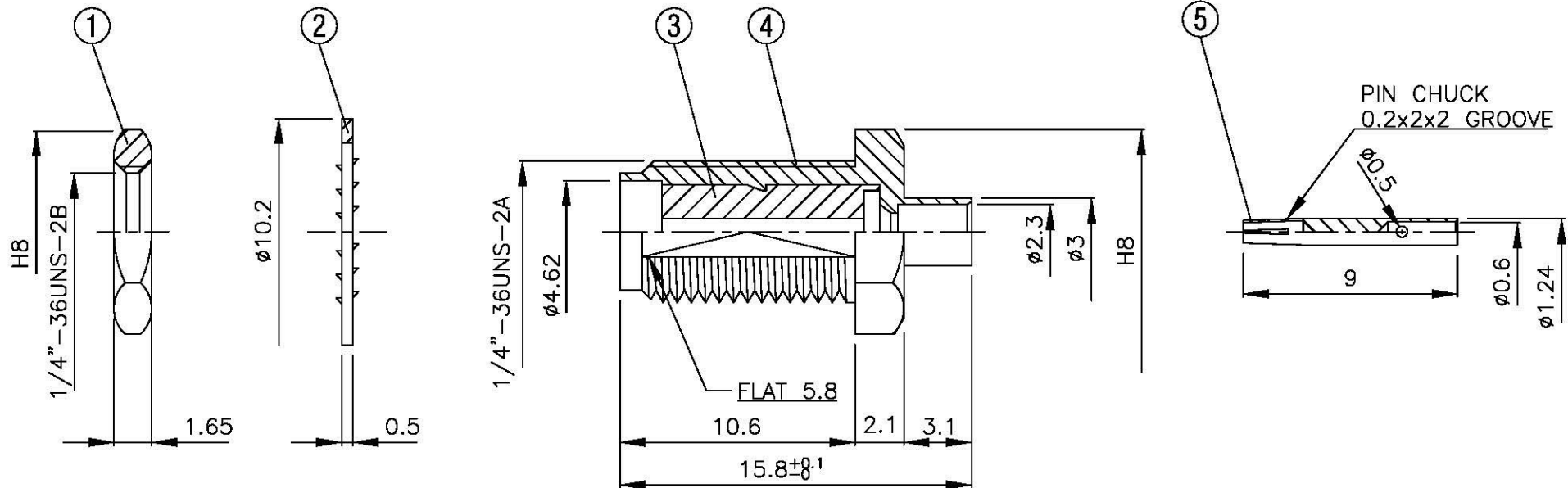

**All Connectors**

www.allconnectors.com info@allconnectors.com  
Tel.: 0340 711 700503 Fax: 0340 711 7009504  
Ziwan Road, Suzhou, China 215000

TITLE SMA FEMALE SOLDER FOR RG 405 (.085)

PART NO. SMA-56V1-TGG

DRAWING NO. SMA 56V1 TGG

DRAWN	MARY	DATE	92.05.06
CHECKED	蘇姿潔	DATE	
Q.A.	馮健華	DATE	
APPROVAL	徐燦霖	DATE	
REVISION		DATE	

DIMENSIONS ARE IN MILLIMETERS			
UNLESS OTHERWISE SPECIFIED TOLERANCE			
0.5-5=±0.2	120-315=±1		
5-30=±0.4	315-1000=±1.6		
30-120±0.6	1000-2000=±2.4		
SCALE	4:1	SIZE	A

REVISION	
DESCRIPTION	ENGINEER

4

3

2

1