

NO	DESCRIPTION	MATERIAL	Q'TY	FINISH	REMARK
1	NUT	BRASS	1	GOKD	N-0006
2	WASHER	BRASS	1	GOKD	W-0016
3	BODY	BRASS	1	GOKD	B-SMA0904-G
4	INSULATION 1	TEFLON	1	TEFLON	I-0131T
5	PIN	BE CU	1	GOLD	P-SMA0635-G
6	INSULATION 2	TEFLON	1	TEFLON	I-0256T
7	BODY	BRASS	1	GOKD	B-SMA0903-G

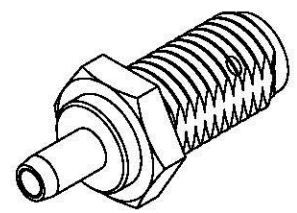

(Recommended Stripping Dimension)

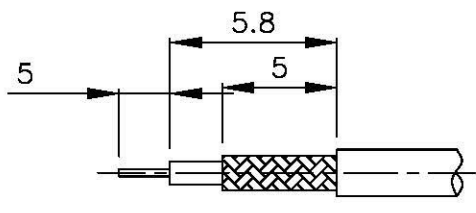
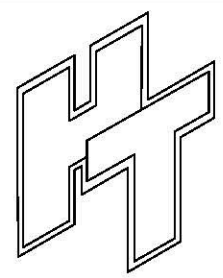
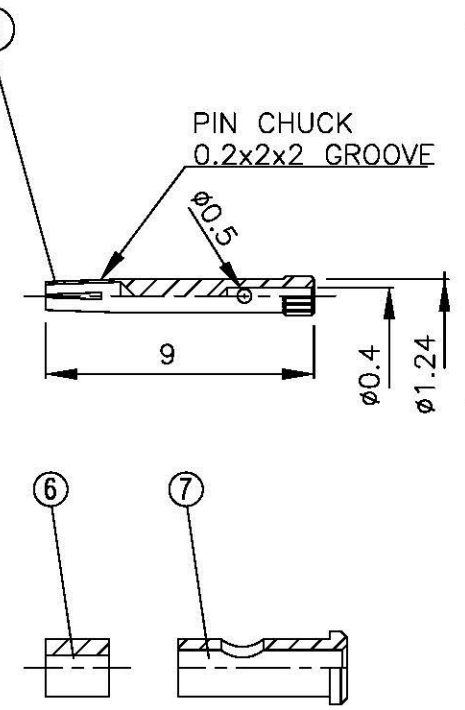
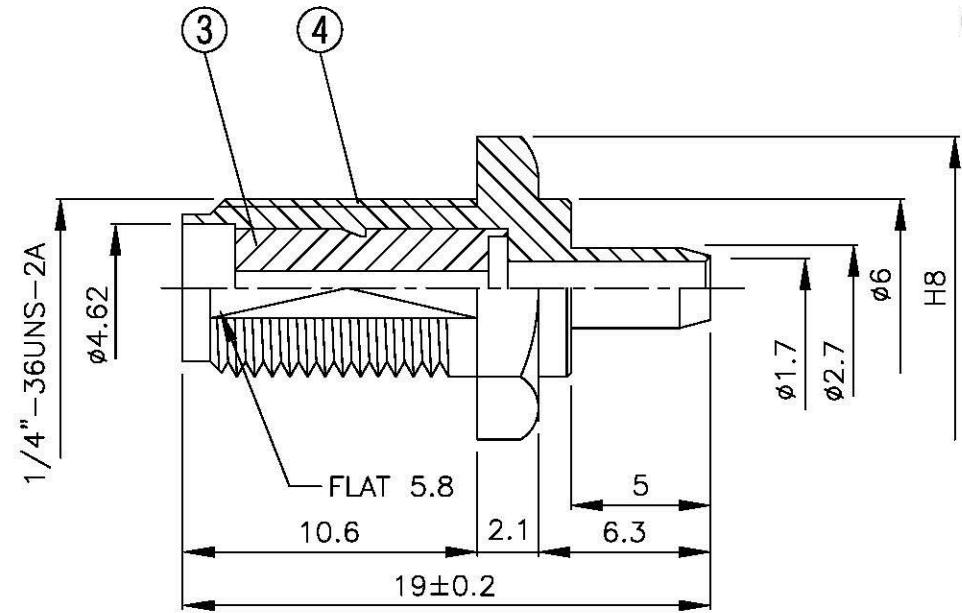
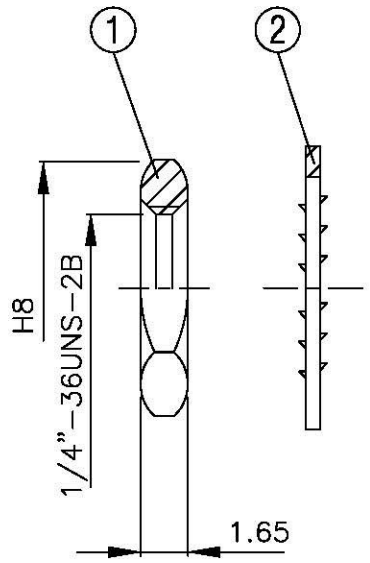

All Connectors
 www.allconnectors.de info@allconnectors.de
 Tel.: +49 69 711 706304 Fax: +49 69 711 706307
 79791 Pfladerstadt - Germany Keitmeistr. 25

TITLE SMA FEMALE CRIMP FOR HRS 0.8mm
 PART NO. SMA-56U2-TGN-1
 DRAWING NO. SMA 56U2 TGN-1

DRAWN MARY DATE 96.03.20
 CHECKED 黄巧君 DATE 96.03.20
 Q.A. 蘇姿潔
 APPROVAL 徐燦霖
 REVISION DATE

DIMENSIONS ARE IN MILLIMETERS
 UNLESS OTHERWISE SPECIFIED TOLERANCE
 0.5-5=±0.2 120-315=±1
 5-30=±0.4 315-1000=±1.6
 30-120±0.6 1000-2000=±2.4
 SCALE 4:1 SIZE A

REVISION
 DESCRIPTION ENGINEER