

NO	DESCRIPTION	MATERIAL	Q'TY	FINISH	REMARK
1	SHELL	BRASS	1	NICKEL	B-SMA0043-N
2	GASKET	SI RUBBER	1	RUBBER	RU-0008
3	WASHER	PH.BRONZE	1	NICKEL	W-0012
4	BODY	BRASS	1	NICKEL	B-SMA0745-N
5	INSULATION	TEFLON	1	TEFLON	I-0132T
6	PIN	BRASS	1	GOLD	P-SMA0103-G

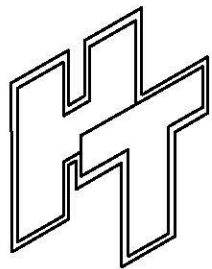
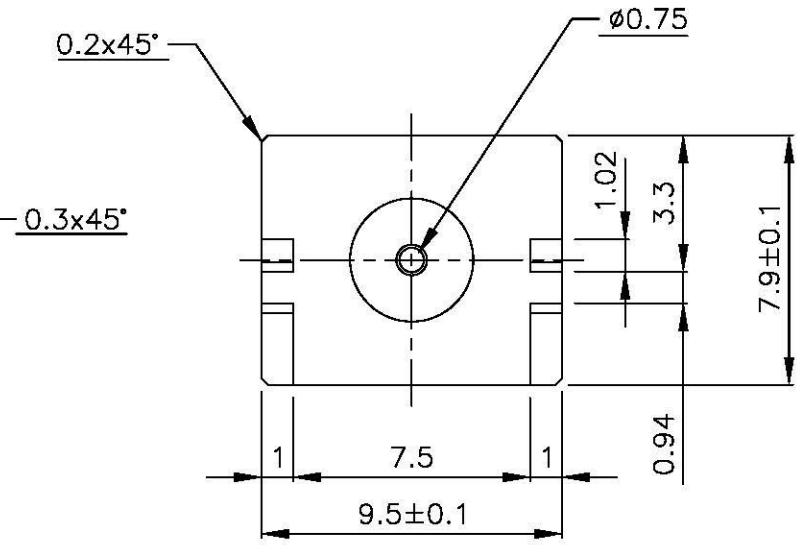
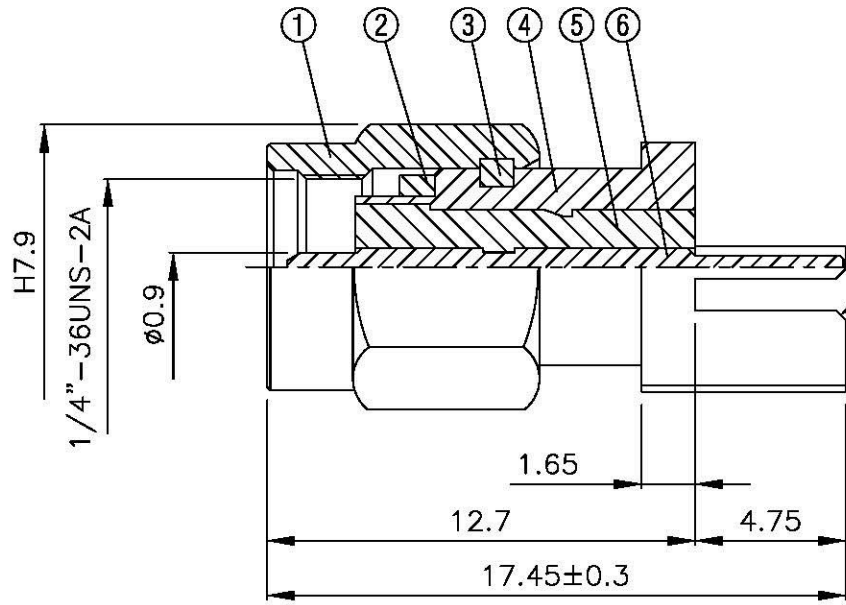
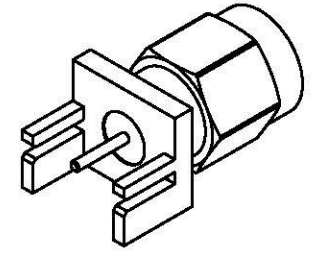

**All Connectors**  
 www.allconnectors.de    info@allconnectors.de  
 Tel: +49 33 731 203503    Fax: +49 33 731 203504  
 20254 Finkenwerder • Germany    Email: order@allc.de

TITLE SMA MALE END LAUNCH  
 (BOARD THICKNESS 0.79)

PART NO. SMA-50V6-TGN

DRAWING NO. SMA 50V6 TGN

DRAWN MARY    DATE 96.03.27

CHECKED 黄巧君    DATE

Q.A. 蘇姿潔    DATE

APPROVAL 徐燦霖    DATE

REVISION    DATE

DIMENSIONS ARE IN MILLIMETERS

UNLESS OTHERWISE SPECIFIED TOLERANCE

0.5-5=±0.2	120-315=±1
5-30=±0.4	315-1000=±1.6
30-120±0.6	1000-2000=±2.4

SCALE 4:1    SIZE A

REVISION	
DESCRIPTION	ENGINEER