

NO	DESCRIPTION	MATERIAL	Q'TY	FINISH	REMARK
1	SHELL	BRASS	1	NICKEL	B-SMA0043-N
2	GASKET	SI RUBBER	1	RUBBER	RU-0008
3	WASHER	PH.BRONZE	1	NICKEL	W-0012
4	BODY	BRASS	1	NICKEL	B-SMA0160-N
5	INSULATION	TEFLON	1	TEFLON	I-0132T
6	PIN	BRASS	1	GOLD	P-SMA0103-G

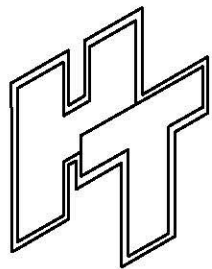
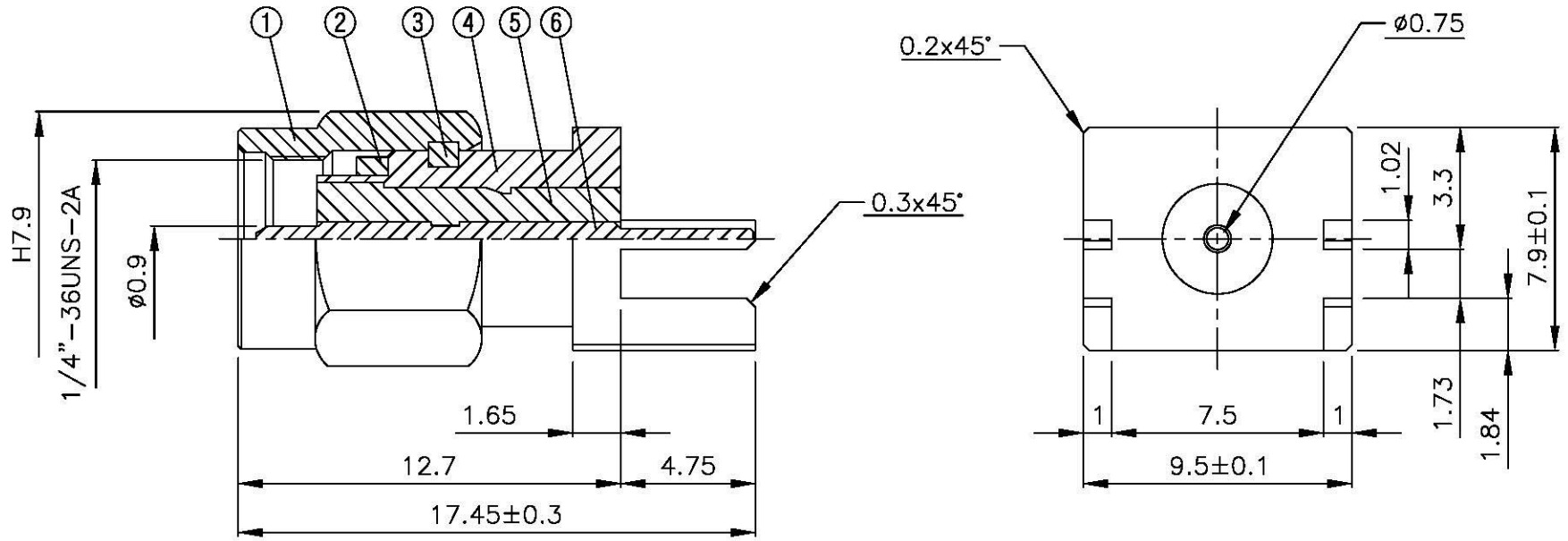
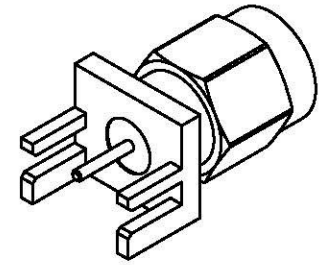

All Connectors

www.allconnectors.de info@allconnectors.de
 TEL: 0049 721 706900 FAX: 0049 721 706904
 70734 Filzschlößl - Germany Kellerstr. 25

TITLE SMA MALE END LAUNCH
 TAB CONTACT (BOARD THICKNESS 1.57)

PART NO. SMA-50V4-TGN

DRAWING NO. SMA 50V4 TGN

DRAWN	MARY	DATE	96.03.27
CHECKED	蘇姿潔	DATE	
Q.A.	馮健華	DATE	
APPROVAL	徐燦霖	DATE	
REVISION		DATE	

DIMENSIONS ARE IN MILLIMETERS			
UNLESS OTHERWISE SPECIFIED TOLERANCE			
0.5-5=±0.2	120-315=±1		
5-30=±0.4	315-1000=±1.6		
30-120±0.6	1000-2000=±2.4		
SCALE	4:1	SIZE	A

REVISION	
DESCRIPTION	ENGINEER