

NO	DESCRIPTION	MATERIAL	Q'TY	FINISH	REMARK
1	SHELL	BRASS	1	NICKEL	B-SMA0043-N
2	GASKET	SI RUBBER	1	RUBBER	RU-0008
3	WASHER	PH.BRONZE	1	NICKEL	W-0012
4	BODY	BRASS	1	NICKEL	B-SMA1245-N
5	INSULATION	TEFLON	1	TEFLON	I-0132T
6	PIN	BRASS	1	GOLD	P-SMA0886-G

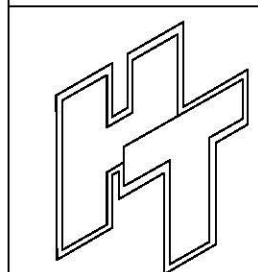
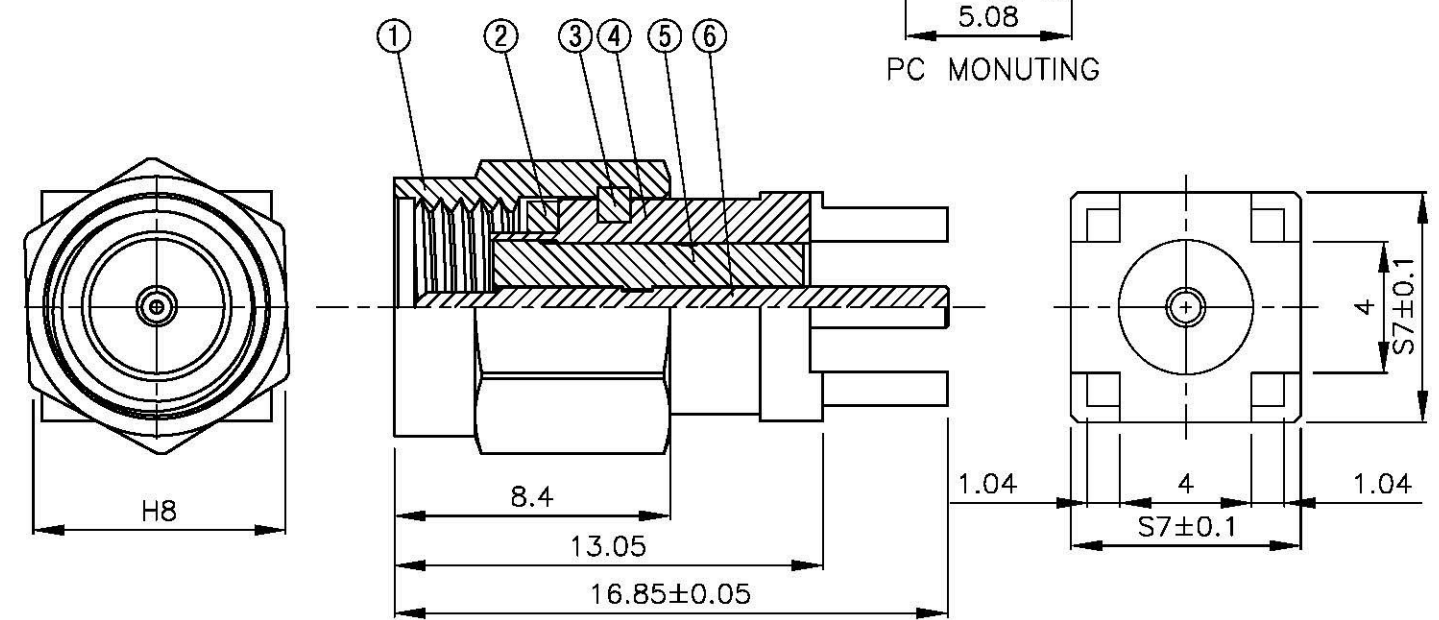
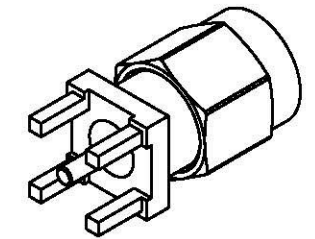
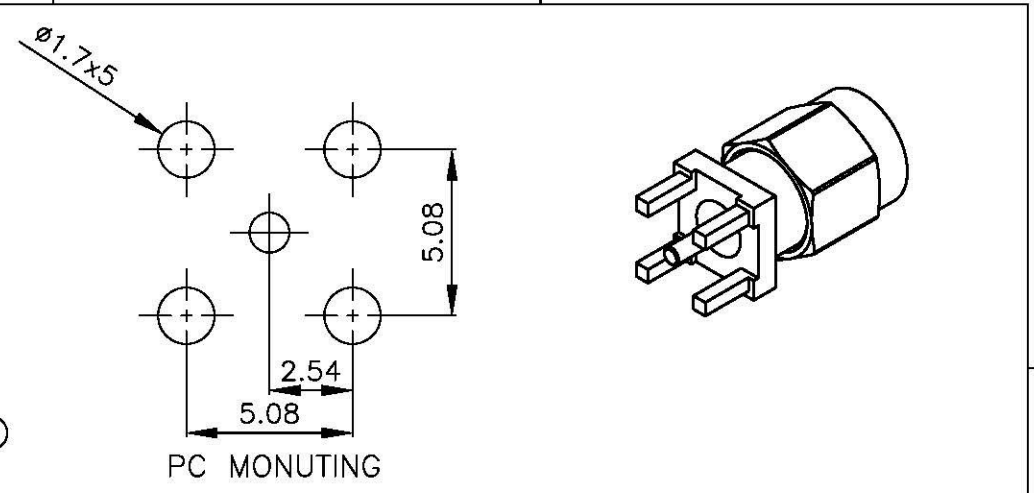

All Connectors
 www.allconnectors.de
 Tel: +49 430 733 70000
 00701 Bielefeld - Germany

TITL
SMA MALE PCB MOUNT

PART NO.
SMA-50-TGG

DRAWING NO.
SMA 50 TGG

DRAWN MARY **DATE** 96.12.03

CHECKED 蘇志欣 **DATE**

Q.A. 蘇姿潔 **DATE**

APPROVAL 徐燦霖 **DATE**

REVISION **DATE**

DIMENSIONS ARE IN MILLIMETERS

UNLESS OTHERWISE SPECIFIED TOLERANCE

0.5-5=±0.2	120-315=±1
5-30=±0.4	315-1000=±1.6
30-120±0.6	1000-2000=±2.4

SCALE 4:1 **SIZE** A

REVISION	
DESCRIPTION	ENGINEER