

NO	DESCRIPTION	MATERIAL	Q'TY	FINISH	REMARK
1	PIN	BE CU	1	GOLD	P-SMA0064-G
2	BODY 1	BRASS	1	GOLD	B-SMA0238-G
3	NUT 1	BRASS	1	GOLD	N-0020-G
4	INSULATION 1	TEFLON	1	TEFLON	I-0047T
5	BODY 2	BRASS	1	GOLD	B-SMA0232-G
6	INSULATION 2	TEFLON	1	TEFLON	I-0046T
7	WASHER	BRASS	1	GOLD	W-0016
8	NUT 2	BRASS	1	GOLD	N-0006-G

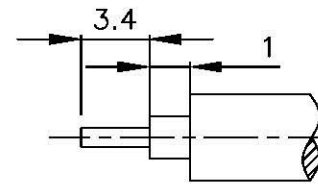

(Recommended Stripping Dimension)

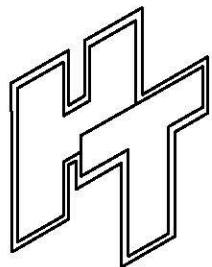
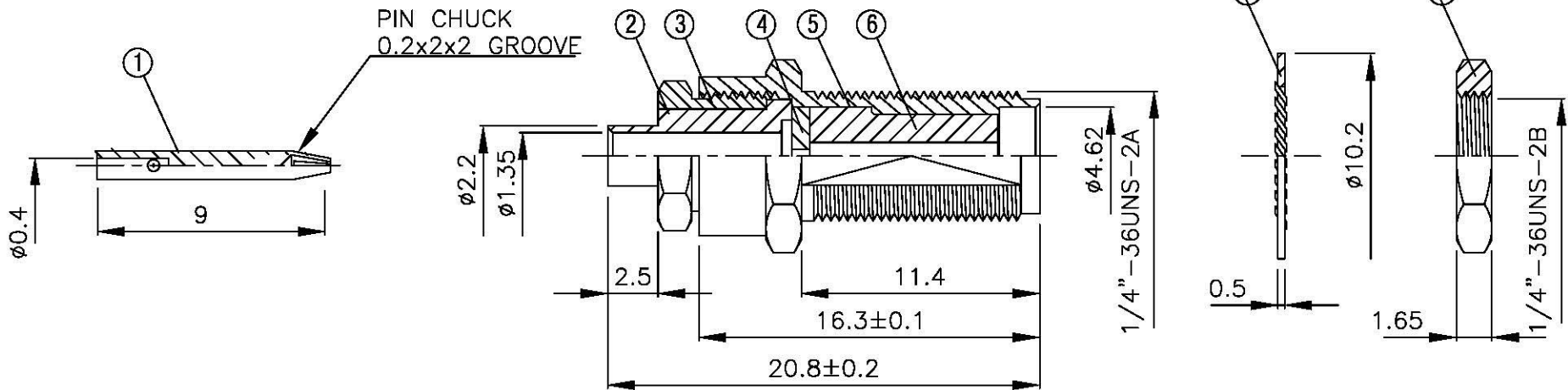
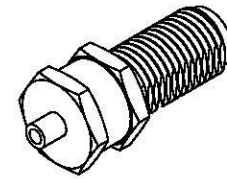

All Connectors
 www.allconnectors.de
 info@allconnectors.de
 Tel: +49 711 204552
 Fax: +49 711 204547
 70774 Ellersried - Germany
 Kellerei 11, 25

TITLE SMA FEMALE SOLDER FOR .047

PART NO. SMA-44V3-TGG

DRAWING NO. SMA 44V3 TGG

DRAWN MARY DATE 96.03.15

CHECKED 蘇姿潔 DATE

Q.A. 馮健華 DATE

APPROVAL 徐燦霖 DATE

REVISION DATE

DIMENSIONS ARE IN MILLIMETERS

UNLESS OTHERWISE SPECIFIED TOLERANCE

0.5-5=±0.2	120-315=±1
5-30=±0.4	315-1000=±1.6
30-120±0.6	1000-2000=±2.4

SCALE 4:1 SIZE A

REVISION

DESCRIPTION	ENGINEER